

hydroo®

VDR00 SERIES

VTP

VTPS

VTPM

High pressure
twin pump sets





PRESENTATION

HYDROO has set up a worldwide distribution network together with key partners, providing value to our pump engineers and end users. Ours is a wide range product portfolio with high-end solutions for the pumping business in many applications including water supply, booster sets, fire-fighting sets, borehole wells, HVAC, drainage and sewage, utilities, irrigation, desalination and RO sets, OEM integration among many others. We provide solutions for all the markets of 50 Hz and 60 Hz, including customized versions.

HYDROO has a factory in Palol de Revardit (Catalonia-Spain) sized to guarantee our reliable, long-term based, personalized treatment and best service to all our customers. We can provide a wide range of products in an extremely short delivery time from our factory, thanks to our lean manufacturing processes and our qualified enthusiastic team.

We have compiled our commitment with ethics and legislation in relation to third parties in a public document of principles. The document has been worked with the entire HYDROO team and its deployment has been started with a committee that will ensure compliance and strengthening in the business culture of the company.

The expansion of HYDROO by means of excellence in operations and successful business relationship with our partners is symbolized in the growth pace in the target markets and the valuable timely and effective service.

At HYDROO we bet on a high level service to our valued pump partners.

INTRODUCTION

PUMP Range presentation and main features

VDROO is a new series of vertical multistage centrifugal pumps made by Hydroo. It includes different versions: VF, VX, VN and VD and their corresponding pumps sets with motor and with variable frequency drivers.

VDROO range has been designed to meet the highest demanding in pumping installations. It has been designed, engineered, industrialized and finally, is being produced in the main factory of Hydroo in Palol de Revardit, Catalonia-Spain.



Main technical benefits

VDROO range is ready to meet the most demanding applications and it is able to suit to any pumping installation with the best technical results.

- Cartridge mechanical seal for an easy seal maintenance without need to remove the motor

- Wide range of connections to match the installation requirements: oval, rounded, threaded, Victaulic

- Wide variety of materials. All parts in contact with the pumped liquid can be made of AISI304 SS (VX), AISI316 SS (VN), Mixed with cast iron and AISI304 SS (VF) or even in Duplex SS (VD) for specific sizes

- Readiness to a wide variety of liquids by means of using the right pump materials, as well as o-rings or mechanical seals

- All pumps are individually tested and results are always available for customers

- Provides the biggest pumping range in the market starting at 1 m³/h up to 210 m³/h in the BEP. All in just 13 sizes to optimise pump's selection

- All the range is energy-optimised and in compliance with the ErP Regulation of the EU Commission nr. 547/2012, providing higher MEI grade than the minimum of the mentioned regulation



Highest pump performance is related to the motor and the hydraulics detailed design. We use the high-end technical resources to reach the best in the market results. Maximised hydraulic efficiency and IE3 standard motors turn out to a unique leading pump concept: robust, reliable, flexible, user-adjustable, smart and multi-purpose.



Our commitment with the environment is in the base of our company thinking. All processes consider the minimum impact in our own home. Within the designing process we had in mind any individual requirement to get the best result for our customers.



Added value relies on material selection, the industrial process of the components production and the usable design of all the single details. Pump flexibility, high line-up of options and personalized service is our added value.



We take care of our customer's pumps. We are our customer's factory and they deserve our full commitment in excellence and exemplary corporate culture. We consider no boundaries within the value chain, starting from industrial installation engineering to pump managing. This vision results in a close cooperation with all players to get the best pumping solution.



Quality assurance is a key factor for added value products. We at Hydroo watch the pump quality, the crafted manufacturing process and expedition quality are integrated in our core service offer. Moreover, variable frequency drivers are available to get the best pump service in any kind of installation. World is in motion and we contribute to it with warmth and commitment.

VTP VTPS VTPM

High pressure twin pump sets

Applications

Water treatment by ultra-filtration
RO systems
Booster systems
High pressure flushing systems
Water supply
Sea water desalination



Description

Twin pump in-line set made in stainless steel.

Standard IE3 motors totally enclosed, fan cooled, insulation class F, IP 55. Pump inlet/outlet bodies are set in serial with Victaulic connections.

Whole pumps available in AISI304, AISI316L or Duplex.

High pressure sets VTPX, VTPN: twin pumps in serial up to 48 bar pressure for RO applications.

VTPS / VTPMD booster sets: twin pumps in serial up to 74 bar for RO applications.

Performance range

Flow range: up to 55 m³/h
Head: up to 740 m
Temperature: up to 70 °C
Speed: 2900 rpm or 3500 rpm
Power: up to 55 kW

Standard material

All the parts in contact with liquid are made of AISI304 SS, AISI316 SS and Duplex available on request.

The pump head and inlet/outlet pump body is made of AISI304, AISI316 SS or Duplex SS precision molding.

Motor

Full-enclosed efficiency standard motor air cooled according IEC634-2014

Protection class:IP55

Insulation class: F

Standard voltage: 50HZ:

1x230V
3x230/400V
3x400/690V

Working conditions

– Thin, clean, non-flammable and nonexplosive liquid containing no solid granules and fibers.

– Liquid temperature: -15 °C +120 °C

– Ambient temperature: up to +40 °C

– Altitude: up to 1000m

Connection

Inlet & outlet: PJE connection

Performance scope

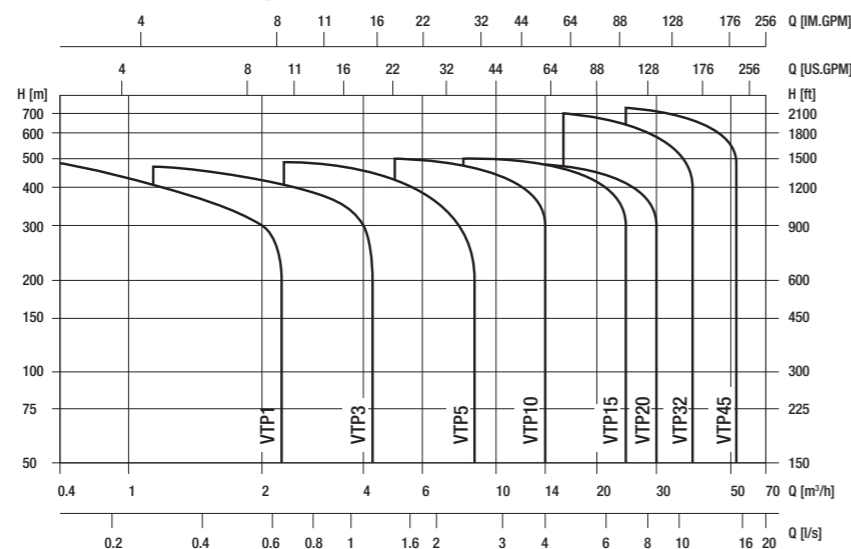

Performance curve

Following conditions are suitable for the performance curves shown below:

- All curves are based on the measured values of 50HZ: constant motor speed 2900rpm or 2950rpm.
- Curve tolerance in conformity with ISO9906 Annex A.
- Measurement is done with 20°C air-free water, kinematic viscosity of 1mm²/sec.
- The operation of pump shall refer to the performance region indicated by the thickened curve to prevent over-heating due to too small flow rate or overload of motor due to too large flow rate.

Product range

Description	VTP-1	VTP-3	VTP-5	VTP-10	VTP-15	VTP-20	VTPS-32	VTPS-45	VTPM-20	VTPM-45
Rated flow [m³/h]	1	3	5	10	15	20	32	45	20	45
Rated flow [l/s]	0.28	0.83	1.39	2.78	4.17	5.56	8,90	11,70	5.60	11,70
Flow range [m³/h]	0.5~2.4	1.2~4.4	2.5~8.5	5~14	8~24	10~29	16-40	25-55	5-22	20-45
Max. pressure. [bar]	47	46	49	48	47	48	70	72	68	73
Motor power [kW]	0.37~2.2	0.37~3	0.37~5.5	0.75~11	1.1~15	1.1~18.5	4.4~11.1	6.9~15.3	1.4~5.6	5.6~12.5
Temp. [°C]	-15 ~ +120									
Max. efficiency [%]	48	58	70	72	73	73	73	75	73	75
MEI rates	≥ 0,8			≥ 0,7			≥ 0,7	≥ 0,7	≥ 0,6	≥ 0,6
VX, VN	•	•	•	•	•	•	•	•	•	•
VD							•	•	•	•
Type										
Vertical	•	•	•	•	•	•				
Horizontal							•	•	•	•
Pipelines										
PJE coupling	DN32	DN32	DN32	DN50	DN50	DN50	DN50	DN80	DN50	DN80
System										
Two pumps in serial	•	•	•	•	•	•			•	•
Single pump or two pumps in serial							•	•		

Remark: Motor power is the total of two pumps in serial.

Max. working pressure

Model	Max. pressure (bar)
VTP	50
VTPS32-17 – VTPS32-19; VTPS32-10/10	40
VTPS32-11/11 – VTPS32-16/16	63
VTPS32-17/17 – VTPS32-19/19; VTPM20-18/18	75
VTPS45-14; VTPS45-15, VTPS45-8/8	40
VTPS45-9/9- VTPS45-12/12	63
VTPS45-13/13- VTPS45-15/15; VTPM45-15/15	75

Minimum inlet pressure NPSH

In case that the pressure in pump is lower than the steam pressure used to convey liquid, the cavitations will occur. To avoid cavitations, a minimum pressure at the inlet side of the pump shall be guaranteed.

The maximum suction stroke can be calculated with following formula: $H=P_b \times 10.2 - NPSH - H_f - H_v - H_s$
 P_b =atmosphere pressure [bar] (can be set as 1 bar)

In a closed system, P_b means system pressure [bar]

$NPSH$ =Net positive suction head [m] (It can be read out from the point of possible max. Flow rate shown on NPSH curve)
 H_f =Pipeline loss at the inlet[m]
 H_v =Steam pressure[m]
 H_s =Safety margin=Minimum 0.5m delivery head

If the calculated result H is positive, the pump may Run under the max. Suction stroke H .

In case the calculated result H is negative, a delivery head of min. Inlet pressure is necessary.

Operation in parallel connecting several pumps in parallel running will benefit much more than running a single large pump.

Applicable to different working states necessary in a variable flow system. Increasing the possibility of water supply when the pump is in failure, because in case of pump failure, only part of the system flow is effected.

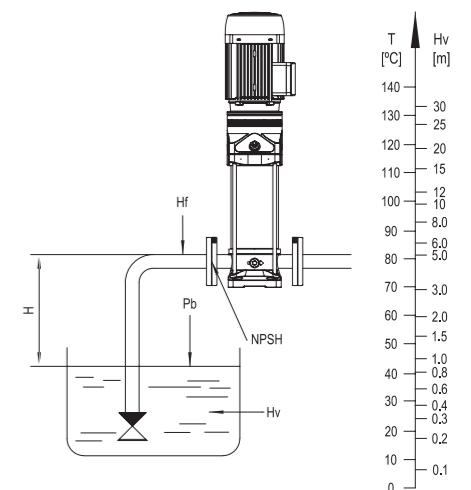

Definition of model

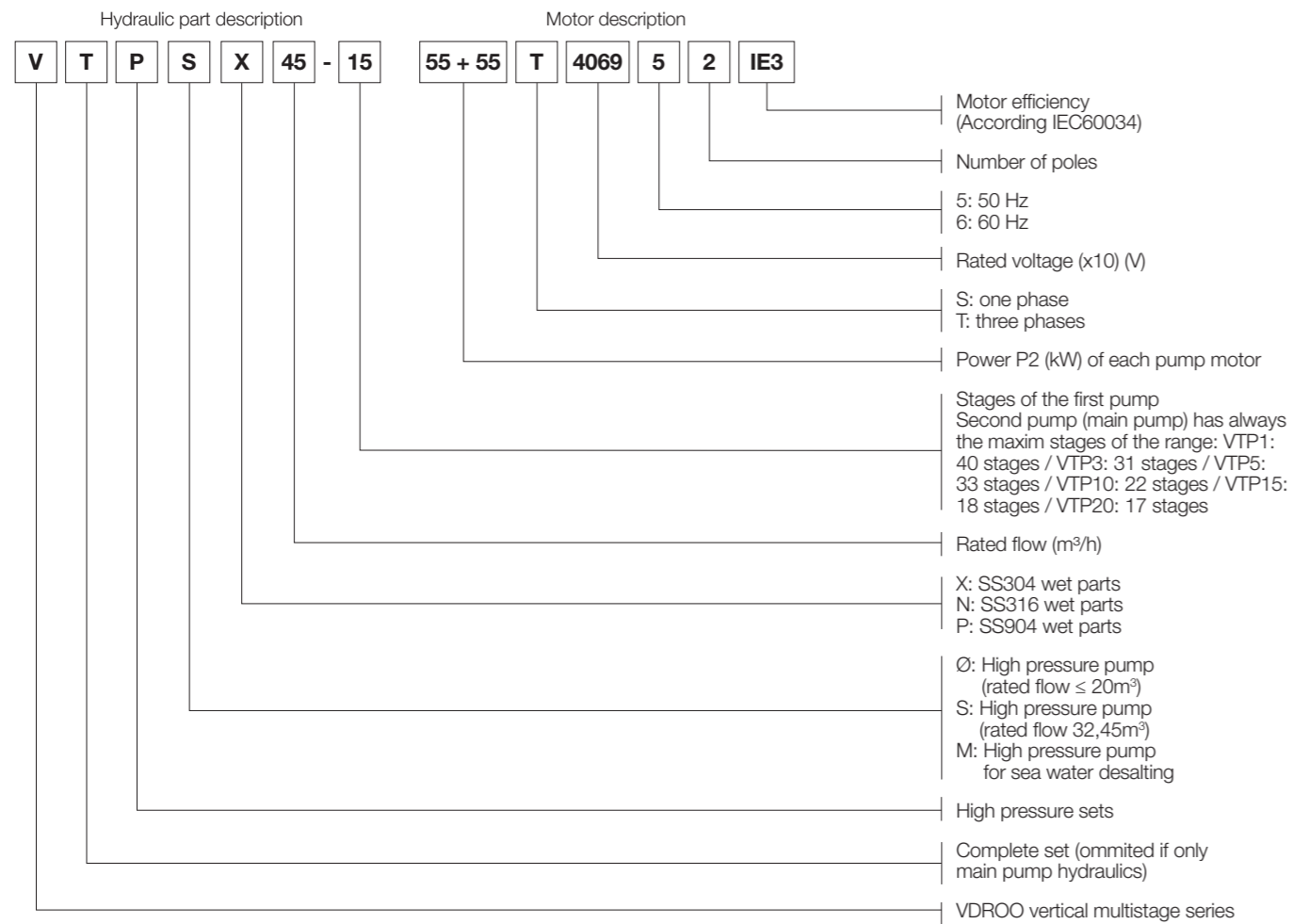

Features

- High pressure
- Simple structure, reliable, high efficient, light and aesthetic
- Cartridge mechanical seal, easy for service

Product Overview

VTP is the new generation of non-self priming high pressure pump with high efficiency. With the new industrial and hydraulic design the pump achieves the efficiency level $MEI >= 0.7$.

This new product has the following advantages: energy saving, lower noise, environment-friendly, modern shape, light weight, easy service and high reliability etc.

The connection in serial of VTP series can create the pressure of 48 bar. The first pump of the set is the water feeding pump, a standard VDROO type, the second pump of the set is a special type designed for the application of high pressure; is non-self priming vertical multistage pump, the rotation direction is contrary to that of the VDROO type. The inlet and outlet chamber is inverted, the flow direction is correspondingly adverse, so the cylinder and mechanical seal only bear the pressure from the outlet of VDROO type, the reliability is therefore enhanced. This catalogue presents the technical information of the whole set.

VTPS, VTPM

- Two pumps assembled to pump sets in serial or only one pump, pump is coupled with standard motor by rigid coupling.
- Pump is installed horizontally.
- Impellers are installed back to back, so as to balance the big trust force of the pump.
- For the wet parts, for VTPS model, it is SS304 or SS316; for VTPM, for precision molding part, the material is duplex stainless steel, for sectional material part, the material is super austenitic stainless steel.

Sectional drawing

VTP1, VTP3, VTP5

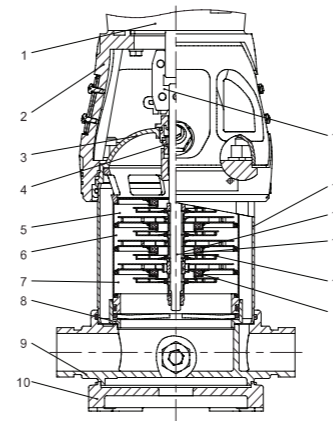

VTP10, VTP15, VTP20

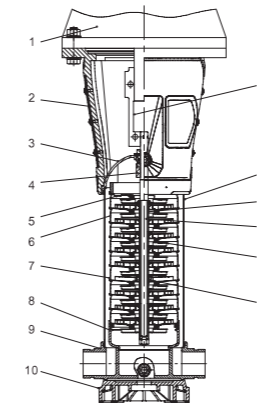

Material

N°	Name	Material	AISI /ASTM
1	Motor		
2	Pump head	Cast iron	ASTM80-55-06
3	Lining		
4	Mechanical seal		
5	Top diffuser	Stainless steel	AISI304
6	Diffuser	Stainless steel	AISI304
7	Support diffuser	Stainless steel	AISI304
8	Inducer	Stainless steel	AISI304
9	Inlet and outlet chamber	Stainless steel	AISI304
10	Base plate	Cast iron	
11	Bearing	Turgsten carbide	
12	Impeller	Stainless steel	AISI304
13	Shaft	Stainless steel	AISI304 AISI316L
14	Impeller sleeve	Stainless steel	AISI304
15	Cylinder	Stainless steel	AISI304
16	Coupling	Carbon steel	

VTPS, VTPM

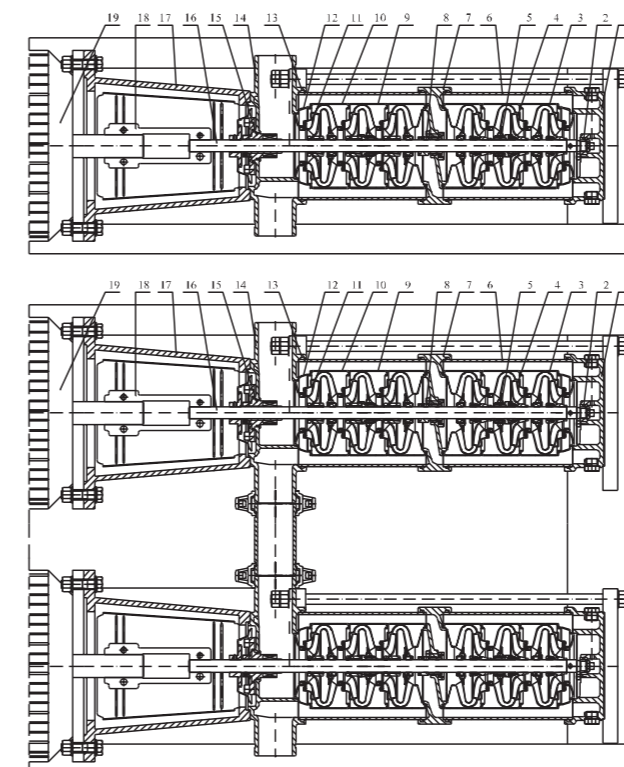

1. Base
2. Bottom bearing
3. Chamber
4. Impeller
5. Intermediate bearing
6. Outer sleeve
7. Exchange chamber
8. Exchange chamber bearing
9. Support reverse chamber
10. Reverse chamber
11. Reverse impeller
12. Inducer
13. O ring
14. Inlet and outlet chamber
15. Mechanical seal
16. Pump shaft
17. Bracket
18. Coupling
19. Motor

VTP1

Installation sketch

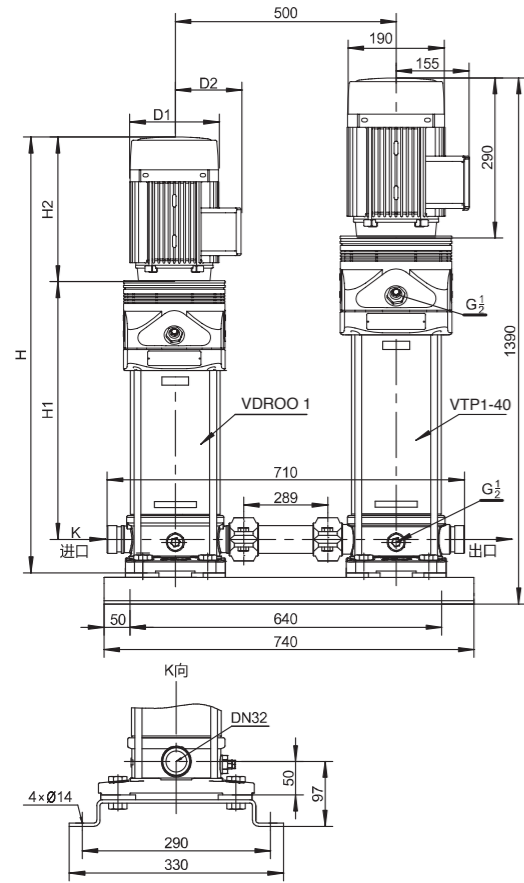

Size and weight

Model	Pump and motor dimensions					Weight (kg)
	H1	H2	H	D1	D2	
VTP1-2	187	215	452	148	117	83
VTP1-3	207	215	472	148	117	83
VTP1-4	227	215	492	148	117	84
VTP1-5	247	215	512	148	117	84
VTP1-6	267	215	532	148	117	85
VTP1-7	287	215	552	148	117	85
VTP1-8	307	215	572	148	117	87
VTP1-9	327	215	592	148	117	87
VTP1-10	347	215	612	148	117	88
VTP1-11	367	215	632	148	117	88
VTP1-12	397	245	692	170	142	91
VTP1-13	417	245	712	170	142	91
VTP1-15	457	245	752	170	142	92
VTP1-17	497	245	792	170	142	95
VTP1-19	537	245	832	170	142	96
VTP1-21	577	245	872	170	142	97
VTP1-22	597	245	892	170	142	97
VTP1-23	627	290	967	190	155	103
VTP1-25	667	290	1007	190	155	104
VTP1-27	707	290	1047	190	155	105
VTP1-30	767	290	1107	190	155	106
VTP1-32	807	290	1147	190	155	109
VTP1-33	827	290	1167	190	155	109
VTP1-34	847	290	1187	190	155	110
VTP1-36	887	290	1227	190	155	111
VTP1-38	927	290	1267	190	155	111
VTP1-40	967	290	1307	190	155	112

Performance table

Model	Motor (kW)	Q (m³/h)	H (m)											
			0	0,5	0,7	1	1,2	1,4	1,6	1,8	2	2,2	2,4	
VTP1-2	0.37+2.2		246	245	242	233	226	214	201	185	165	141	108	
VTP1-3	0.37+2.2		252	251	248	239	231	219	205	189	168	144	110	
VTP1-4	0.37+2.2		258	257	253	244	237	224	210	193	172	147	112	
VTP1-5	0.37+2.2		263	262	259	250	242	229	214	197	175	150	114	
VTP1-6	0.37+2.2		269	268	265	255	247	235	219	201	179	153	116	
VTP1-7	0.37+2.2		275	274	271	262	253	240	224	205	182	156	119	
VTP1-8	0.55+2.2		281	280	276	266	258	245	229	210	187	160	122	
VTP1-9	0.55+2.2		287	286	282	272	263	249	233	214	190	163	124	
VTP1-10	0.55+2.2		293	292	288	278	268	255	238	219	195	167	127	
VTP1-11	0.55+2.2		298	297	294	284	274	260	243	223	198	169	129	
VTP1-12	0.75+2.2		304	303	299	290	280	266	249	229	204	173	132	
VTP1-13	0.75+2.2		310	309	305	296	286	271	253	233	207	176	135	
VTP1-15	0.75+2.2		322	321	316	307	297	281	263	242	215	183	140	
VTP1-17	1.1+2.2		333	332	328	318	307	291	273	250	222	189	145	
VTP1-19	1.1+2.2		346	345	339	329	319	303	283	259	230	195	150	
VTP1-21	1.1+2.2		358	357	351	340	329	312	292	267	236	201	154	
VTP1-22	1.1+2.2		364	363	357	345	334	317	297	272	241	205	158	
VTP1-23	1.5+2.2		370	369	363	351	339	323	303	279	249	212	162	
VTP1-25	1.5+2.2		382	381	375	362	350	333	313	288	256	219	167	
VTP1-27	1.5+2.2		393	392	386	373	361	343	322	296	264	226	173	
VTP1-30	1.5+2.2		411	410	405	390	377	359	337	310	276	236	181	
VTP1-32	2.2+2.2		423	422	417	403	390	371	347	320	287	246	189	
VTP1-33	2.2+2.2		429	428	423	409	396	376	352	325	291	249	191	
VTP1-34	2.2+2.2		434	433	429	415	400	381	357	329	295	253	194	
VTP1-36	2.2+2.2		446	445	440	426	412	391	367	338	303	260	199	
VTP1-38	2.2+2.2		459	458	452	438	424	402	377	348	311	267	205	
VTP1-40	2.2+2.2		471	470	464	449	435	413	387	357	319	274	210	

Performance curve ISO9906 Annex A 2950rpm

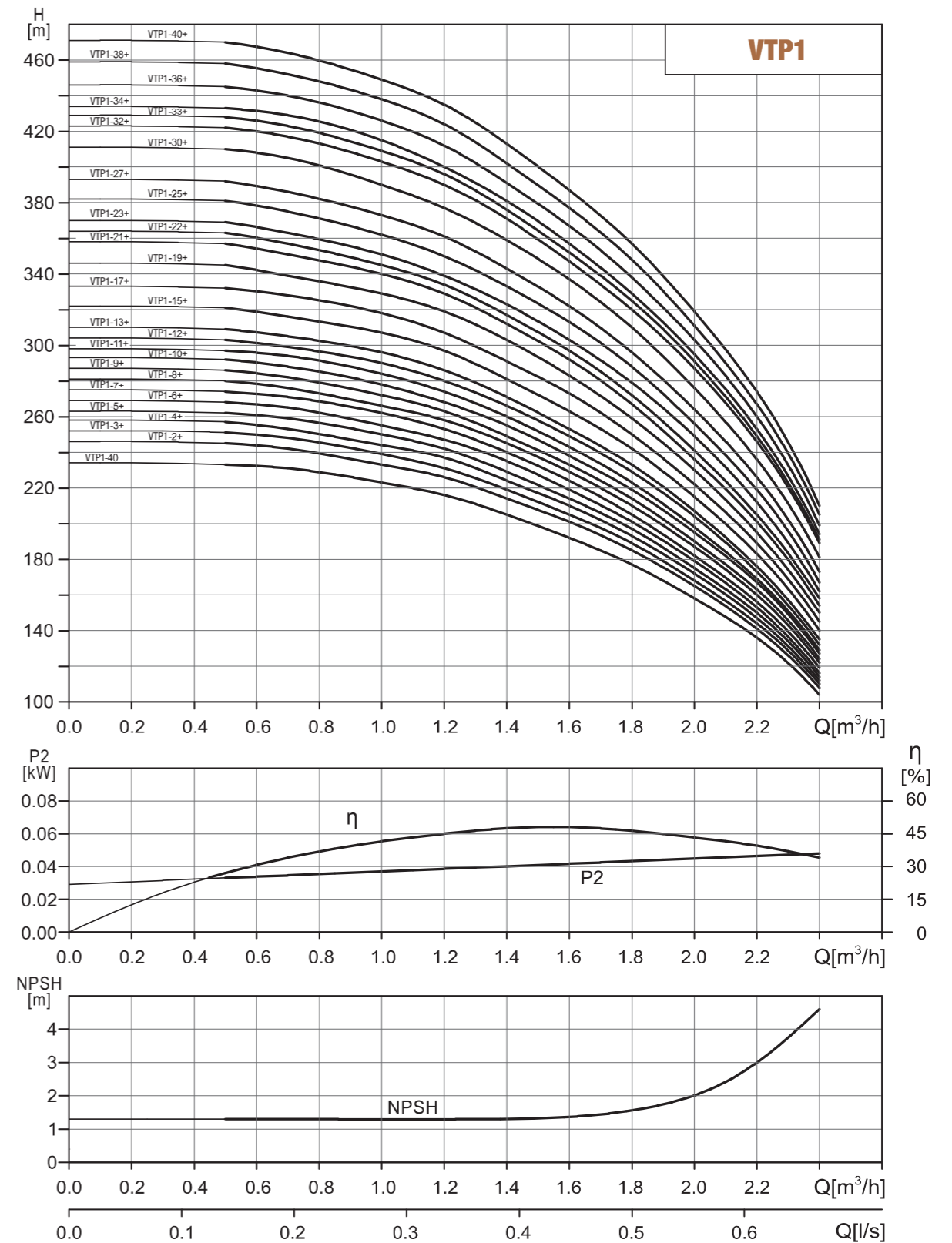

VTP3

Installation sketch

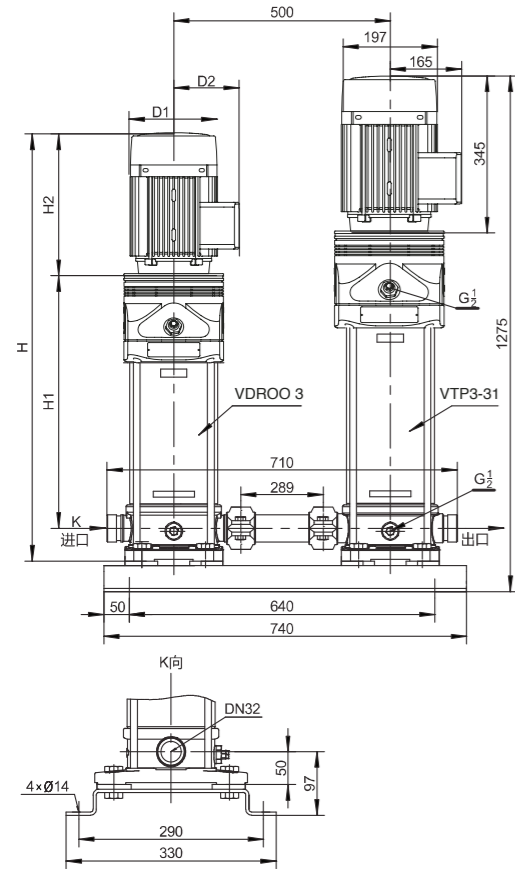

Size and weight

Model	Pump and motor dimensions					Weight (kg)
	H1	H2	H	D1	D2	
VTP3-2	187	215	452	148	117	90
VTP3-3	207	215	472	148	117	90
VTP3-4	227	215	492	148	117	91
VTP3-5	247	215	512	148	117	92
VTP3-6	267	215	532	148	117	93
VTP3-7	297	245	592	170	142	96
VTP3-8	317	245	612	170	142	96
VTP3-9	337	245	632	170	142	98
VTP3-10	357	245	652	170	142	99
VTP3-11	377	245	672	170	142	99
VTP3-12	397	245	692	170	142	100
VTP3-13	427	290	767	190	155	105
VTP3-14	447	290	787	190	155	106
VTP3-15	467	290	807	190	155	106
VTP3-16	487	290	827	190	155	107
VTP3-18	527	290	867	190	155	109
VTP3-19	547	290	887	190	155	110
VTP3-20	567	290	907	190	155	110
VTP3-21	587	290	927	190	155	111
VTP3-22	607	290	947	190	155	111
VTP3-23	627	290	967	190	155	112
VTP3-24	647	290	987	190	155	122
VTP3-25	677	345	1072	197	165	123
VTP3-27	717	345	1112	197	165	124
VTP3-28	737	345	1132	197	165	124
VTP3-29	757	345	1152	197	165	124
VTP3-31	797	345	1192	197	165	125

Performance table

Model	Motor (kW)	Q (m³/h)	0	1,2	1,6	2	2,4	2,8	3	3,2	3,6	4	4,4
VTP3-2	0.37+3	H (m)	246	241	234	226	216	202	195	186	166	140	110
VTP3-3	0.37+3		254	248	242	233	223	209	201	192	171	144	113
VTP3-4	0.37+3		261	256	249	240	229	215	207	197	176	149	117
VTP3-5	0.55+3		269	263	256	246	235	221	213	203	181	153	120
VTP3-6	0.55+3		276	270	263	254	242	227	219	209	186	157	123
VTP3-7	0.75+3		284	278	271	262	249	234	225	215	191	162	127
VTP3-8	0.75+3		291	285	279	269	256	240	231	220	196	166	130
VTP3-9	1.1+3		299	293	286	276	263	247	237	226	201	170	134
VTP3-10	1.1+3		306	300	293	283	269	252	243	231	206	174	137
VTP3-11	1.1+3		314	307	300	290	276	259	249	237	211	179	141
VTP3-12	1.1+3		321	315	307	296	282	265	255	242	215	182	144
VTP3-13	1.5+3		329	322	314	303	289	271	261	248	220	186	148
VTP3-14	1.5+3		337	329	322	311	296	277	267	253	225	190	151
VTP3-15	1.5+3		344	337	329	318	303	285	274	261	232	196	155
VTP3-16	1.5+3		352	345	337	325	310	291	280	267	237	201	158
VTP3-18	2.2+3		367	360	351	339	323	304	292	277	246	208	165
VTP3-19	2.2+3		374	367	358	345	329	310	298	283	252	214	168
VTP3-20	2.2+3		382	375	365	353	336	316	304	289	256	217	171
VTP3-21	2.2+3		389	382	373	360	343	322	310	295	262	222	175
VTP3-22	2.2+3		397	389	379	367	349	328	316	300	266	225	178
VTP3-23	2.2+3		404	397	387	374	356	335	322	306	271	229	182
VTP3-24	2.2+3		412	404	397	381	363	341	328	312	276	233	185
VTP3-25	3+3		419	412	402	388	369	347	334	317	281	237	189
VTP3-27	3+3		435	427	416	401	383	360	346	330	294	249	196
VTP3-28	3+3		443	434	423	408	390	366	352	335	299	253	199
VTP3-29	3+3		451	442	431	416	397	373	359	342	304	258	203
VTP3-31	3+3		466	457	445	429	410	385	371	353	315	266	210

Performance curve ISO9906 Annex A 2950rpm

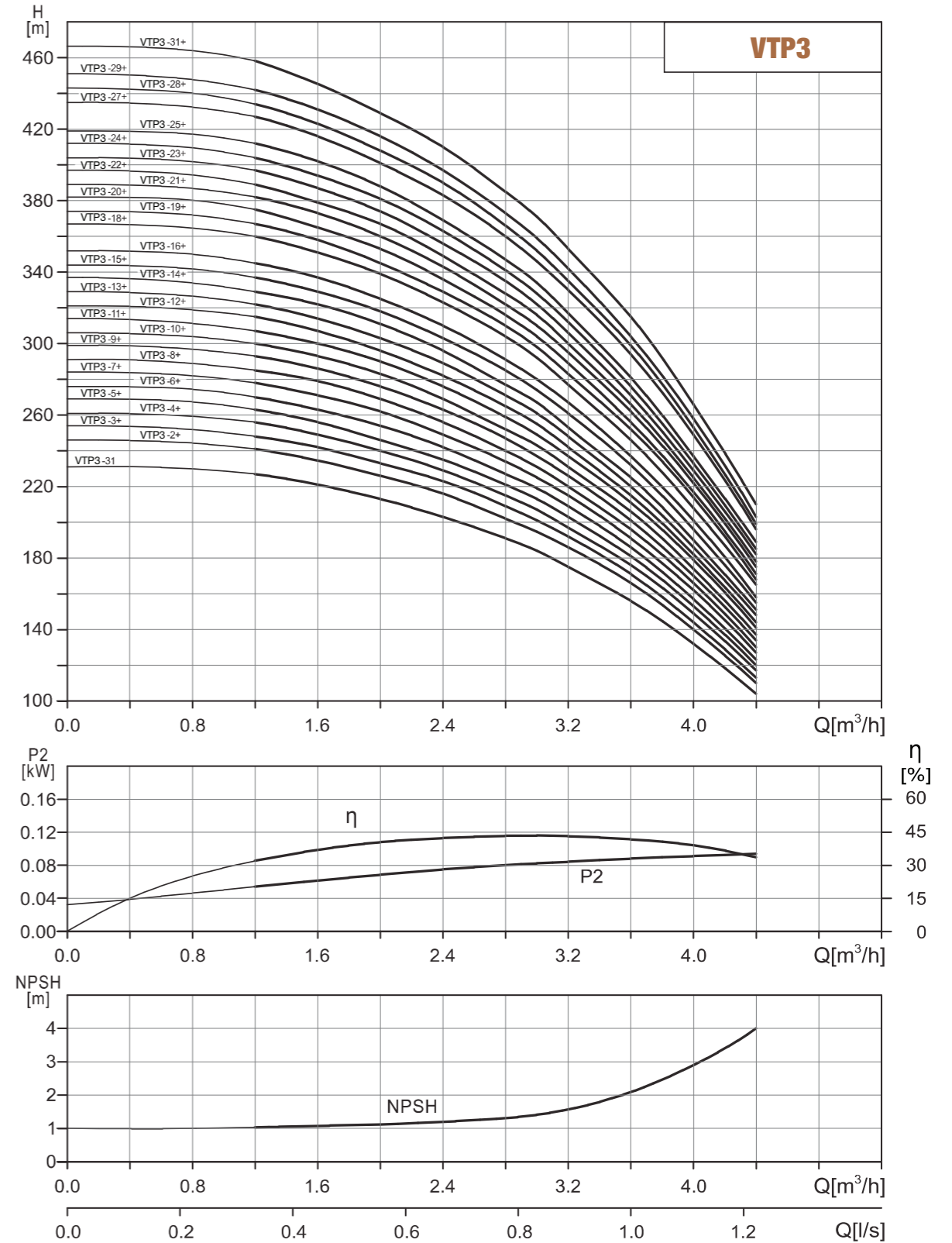

VTP5

Installation sketch

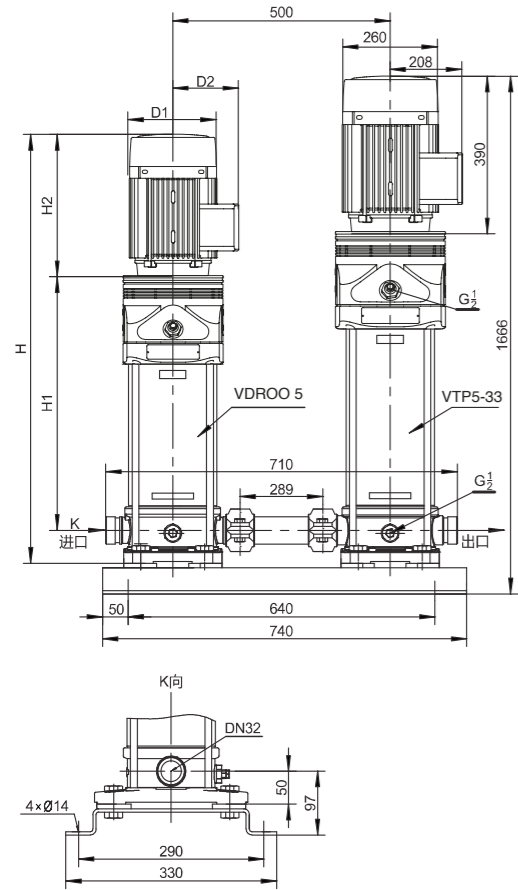

Size and weight

Model	Pump and motor dimensions					Weight (kg)
	H1	H2	H	D1	D2	
VTP5-2	201	215	466	148	117	118
VTP5-3	228	215	493	148	117	120
VTP5-4	255	215	520	148	117	121
VTP5-5	292	245	587	170	142	124
VTP5-6	319	245	614	170	142	126
VTP5-7	346	245	641	170	142	126
VTP5-8	373	245	668	170	142	127
VTP5-9	410	290	750	190	155	132
VTP5-10	437	290	777	190	155	133
VTP5-11	464	290	804	190	155	133
VTP5-12	491	290	831	190	155	136
VTP5-13	518	290	858	190	155	136
VTP5-14	545	290	885	190	155	137
VTP5-15	572	290	912	190	155	137
VTP5-16	599	290	939	190	155	138
VTP5-17	636	345	1030	197	165	149
VTP5-18	663	345	1058	197	165	149
VTP5-20	717	345	1112	197	165	150
VTP5-21	744	345	1139	197	165	151
VTP5-22	771	355	1176	230	188	158
VTP5-23	798	355	1203	230	188	159
VTP5-24	825	355	1230	230	188	159
VTP5-25	852	355	1257	230	188	160
VTP5-27	906	355	1311	230	188	161
VTP5-28	933	355	1338	230	188	161
VTP5-29	1035	390	1475	260	208	181
VTP5-30	1062	390	1502	260	208	182
VTP5-33	1143	390	1583	260	208	183

Performance table

Model	Motor (kW)	Q (m³/h)	0	2.5	3	4	5	6	7	8	8.5
VTP5-2	0.37+5.5	H (m)	260	248	244	231	214	193	164	130	111
VTP5-3	0.55+5.5		267	255	251	238	220	199	169	134	114
VTP5-4	0.55+5.5		275	262	258	245	227	205	174	138	118
VTP5-5	0.75+5.5		282	269	265	252	233	211	180	143	122
VTP5-6	1.1+5.5		290	276	272	259	240	217	184	146	125
VTP5-7	1.1+5.5		297	284	279	265	245	223	189	149	128
VTP5-8	1.1+5.5		304	291	286	272	252	228	193	153	131
VTP5-9	1.5+5.5		312	298	293	279	258	234	199	156	134
VTP5-10	1.5+5.5		320	305	300	285	265	239	203	160	137
VTP5-11	1.5+5.5		327	312	307	292	271	245	208	164	140
VTP5-12	2.2+5.5		335	319	314	300	277	250	212	168	144
VTP5-13	2.2+5.5		342	326	321	306	283	255	217	172	147
VTP5-14	2.2+5.5		350	334	328	312	290	261	222	176	150
VTP5-15	2.2+5.5		357	341	336	319	296	266	226	179	153
VTP5-16	2.2+5.5		365	348	342	326	302	272	231	183	157
VTP5-17	3+5.5		372	355	349	332	308	278	236	187	160
VTP5-18	3+5.5		380	362	356	339	314	283	241	191	163
VTP5-20	3+5.5		394	377	370	352	327	294	250	198	170
VTP5-21	3+5.5		402	384	377	359	333	300	255	202	173
VTP5-22	4+5.5		409	391	384	365	339	306	260	207	177
VTP5-23	4+5.5		417	399	391	372	345	312	265	211	181
VTP5-24	4+5.5		424	406	398	379	352	317	270	215	184
VTP5-25	4+5.5		432	413	405	386	358	323	274	218	187
VTP5-27	4+5.5		447	427	419	399	371	334	284	226	193
VTP5-28	4+5.5		455	435	427	406	377	340	289	230	197
VTP5-29	5.5+5.5		462	442	434	413	383	347	296	236	202
VTP5-30	5.5+5.5		471	450	442	420	389	353	301	240	205
VTP5-33	5.5+5.5		494	472	464	441	409	371	317	252	216

Performance curve ISO9906 Annex A 2950rpm

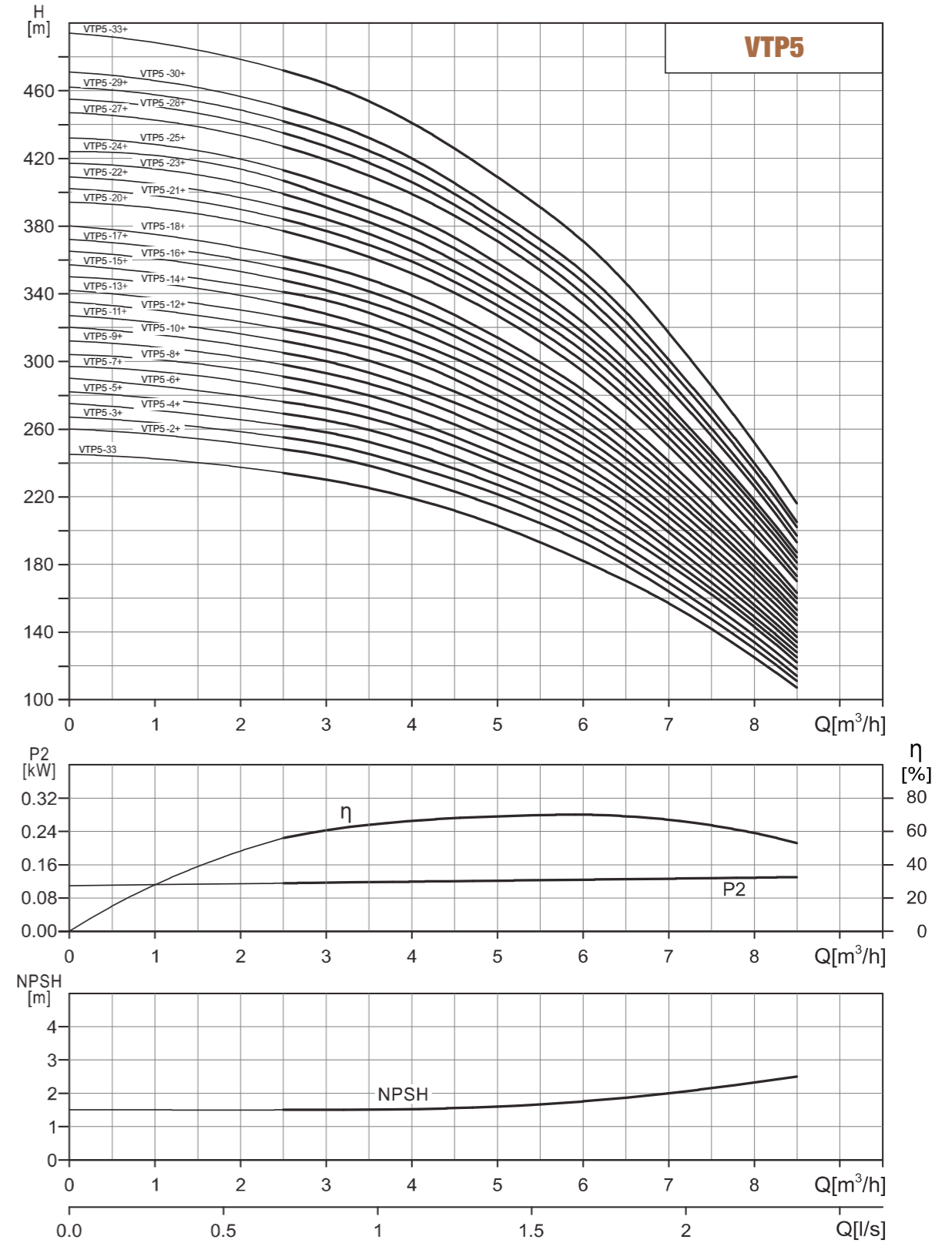

VTP10

Installation sketch

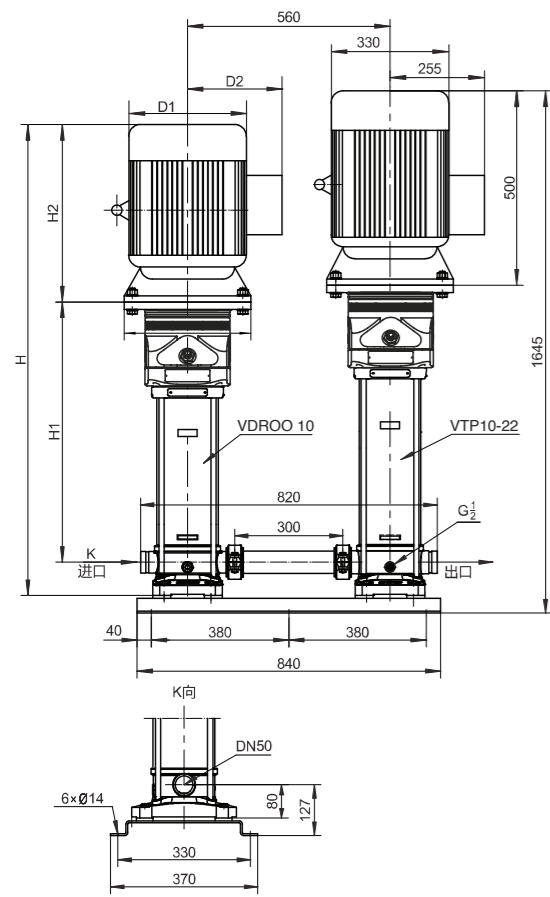

Size and weight

Model	Pump and motor dimensions						Weight (kg)
	H1	H2	H	D1	D2	D3	
VTP10-1	267	245	592	170	142	140	217
VTP10-2	267	245	592	170	142	140	218
VTP10-3	297	245	622	170	142	140	221
VTP10-4	337	290	707	190	155	145	227
VTP10-5	367	290	737	190	155	145	231
VTP10-6	397	290	767	190	155	145	232
VTP10-7	437	345	862	197	165	160	243
VTP10-8	467	345	892	197	165	160	244
VTP10-9	497	355	932	230	188	160	251
VTP10-10	527	355	962	230	188	160	252
VTP10-11	557	355	992	230	188	160	253
VTP10-12	587	355	1022	230	188	160	254
VTP10-13	695	390	1165	260	208	200	274
VTP10-14	725	390	1195	260	208	200	275
VTP10-15	755	390	1225	260	208	200	276
VTP10-16	785	390	1255	260	208	200	285
VTP10-17	815	390	1285	260	208	200	286
VTP10-18	845	390	1315	260	208	200	287
VTP10-19	875	390	1345	260	208	200	288
VTP10-20	905	390	1375	260	208	200	289
VTP10-21	935	390	1405	260	208	200	290
VTP10-22	995	500	1575	330	255	350	356

Performance table

Model	Motor (kW)	Q (m³/h)	0	5	6	8	10	12	14
VTP10-1	0.75+11	H (m)	259	248,2	243	228	209	178	135,5
VTP10-2	0.75+11		270,2	259	253,5	238	217,5	184,5	140,5
VTP10-3	1.1+11		281,2	269,5	264	247,5	226,5	193	147,5
VTP10-4	1.5+11		292,5	280	274	257	235	200	153
VTP10-5	2.2+11		304	290,5	284	267	244	208	159
VTP10-6	2.2+11		315	301	295	277	253	215	165
VTP10-7	3+11		326,5	312	306	288	263	223	171
VTP10-8	3+11		338	323	317	298	272	231	177
VTP10-9	4+11		349,5	334	327	308	281	238	183
VTP10-10	4+11		361	345	338	317	290	247	189
VTP10-11	4+11		372	356	348	327	299	255	195
VTP10-12	4,5+11		385	367	360	338	308	262	201
VTP10-13	5,5+11		395	378	371	349	317	270	207
VTP10-14	5,5+11		408	389	381	358	326	277	213
VTP10-15	5,5+11		419	400	392	368	335	285	219
VTP10-16	7,5+11		431	411	403	378	345	294	225
VTP10-17	7,5+11		442	422	413	388	354	301	231
VTP10-18	7,5+11		453	433	424	399	364	312	239
VTP10-19	7,5+11		465	444	434	409	373	318	244
VTP10-20	7,5+11		476	455	446	419	382	326	251
VTP10-21	7,5+11		488	466	456	429	392	333	257
VTP10-22	11+11		498	478	468	440	402	342	263

Performance curve ISO9906 Annex A 2950rpm

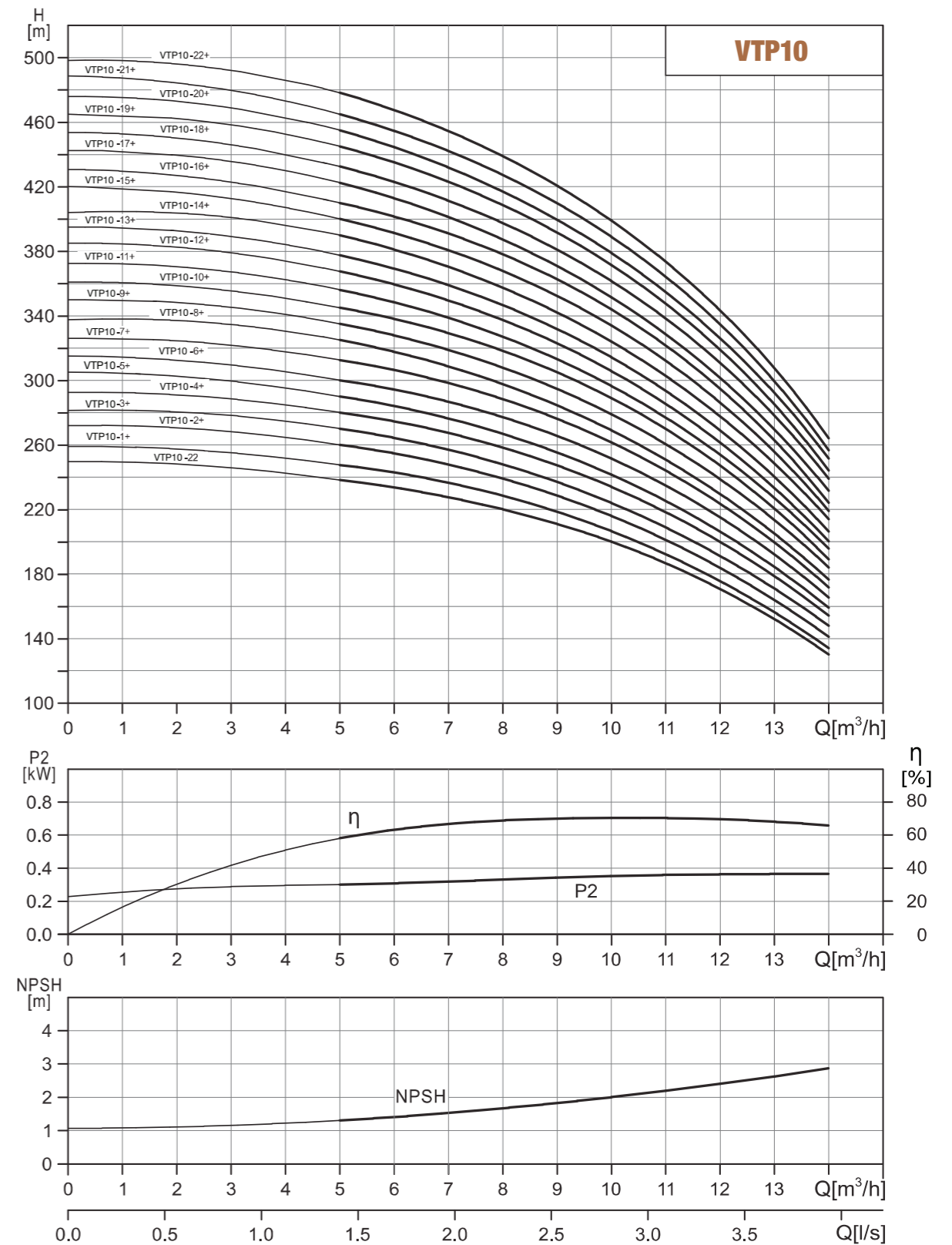

VTP15

Installation sketch

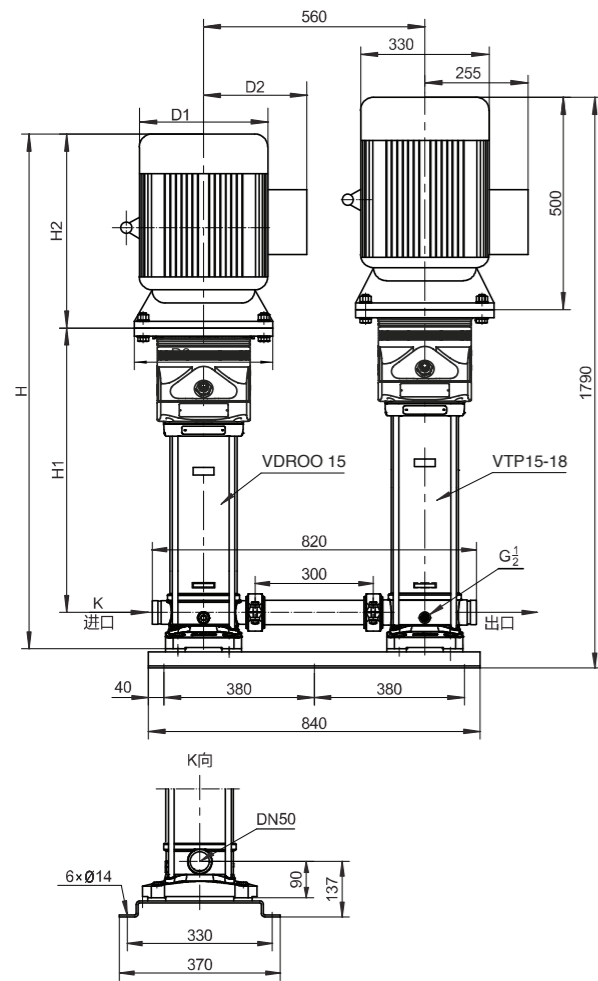

Size and weight

Model	Pump and motor dimensions						Weight (kg)
	H1	H2	H	D1	D2	D3	
VTP15-1	297	245	632	170	142	140	231
VTP15-2	307	290	687	190	155	145	239
VTP15-3	362	345	797	197	165	160	250
VTP15-4	407	355	852	230	188	160	257
VTP15-5	452	355	897	230	188	160	259
VTP15-6	575	390	1055	260	208	200	281
VTP15-7	620	390	1100	260	208	200	282
VTP15-8	665	390	1145	260	208	200	289
VTP15-9	710	500	1190	330	208	200	290
VTP15-10	785	500	1375	330	255	350	348
VTP15-11	830	500	1420	330	255	350	350
VTP15-12	875	500	1465	330	255	350	351
VTP15-13	920	500	1510	330	255	350	353
VTP15-15	965	500	1555	330	255	350	354
VTP15-15	1010	500	1600	330	255	350	370
VTP15-16	1055	500	1645	330	255	350	372
VTP15-17	1100	500	1690	330	255	350	373
VTP15-18	1145	500	1735	330	255	350	375

Performance table

Model	Motor (kW)	Q (m³/h)	H (m)										
			0	8	10	12	14	15	16	18	20	22	24
VTP15-1	1.1+15		260,6	245.2	241	234.8	227.5	222	217.5	205	190	172	146.5
VTP15-2	2.2+15		274	257.5	253	246.5	239	233.5	228.5	215	199	180	153.5
VTP15-3	3+15		288	270.5	266	259.5	251.5	245.5	241	227	210	189	161
VTP15-4	4+15		302	283.5	279	272	263.5	258	253	238	220	198	168.5
VTP15-5	4+15		316	296	291	284	275	269	264	248	229	206.5	176
VTP15-6	5.5+15		330	309	304	296	287	280	274	258	239	216	183
VTP15-7	5.5+15		344	322	317	309	299	292	286	269	249	225	191
VTP15-8	7.5+15		358	335	329	321	311	304	298	280	259	233	199
VTP15-9	7.5+15		372	348	342	334	324	317	310	291	269	242	207
VTP15-10	11+15		386	361	355	347	337	329	322	302	279	251	215
VTP15-11	11+15		399	375	369	360	349	341	333	312	288	259	223
VTP15-12	11+15		414	387	381	372	361	353	345	324	298	268	230
VTP15-13	11+15		428	400	393	383	371	363	355	333	307	277	239
VTP15-15	11+15		442	413	406	396	384	376	367	344	317	286	246
VTP15-15	15+15		456	429	421	411	398	389	380	356	328	296	256
VTP15-16	15+15		470	442	434	423	410	400	391	367	338	306	265
VTP15-17	15+15		484	455	447	436	422	412	403	378	348	315	272
VTP15-18	15+15		498	468	460	448	434	424	414	389	358	324	281

Performance curve ISO9906 Annex A 2950rpm

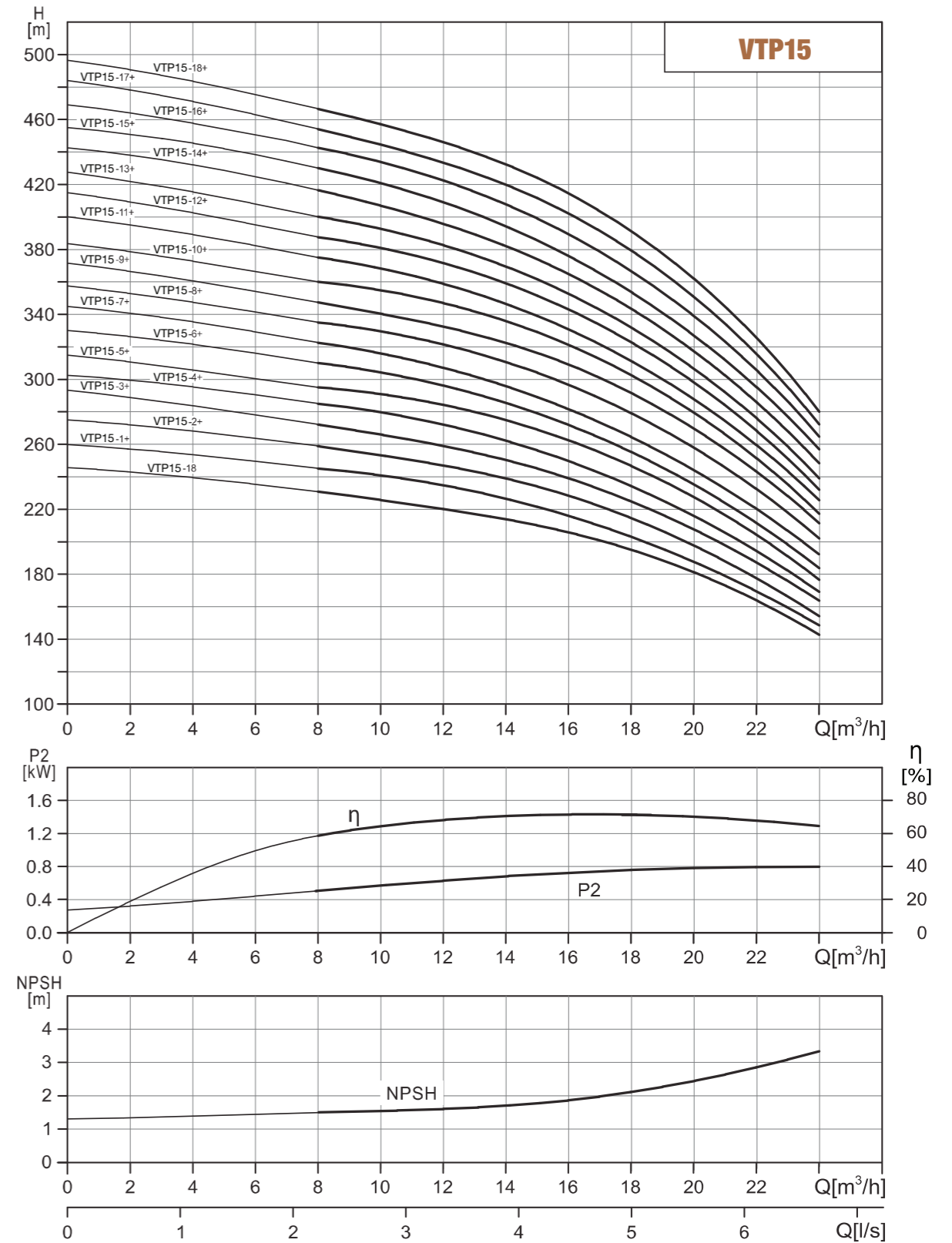

VTP20

Installation sketch

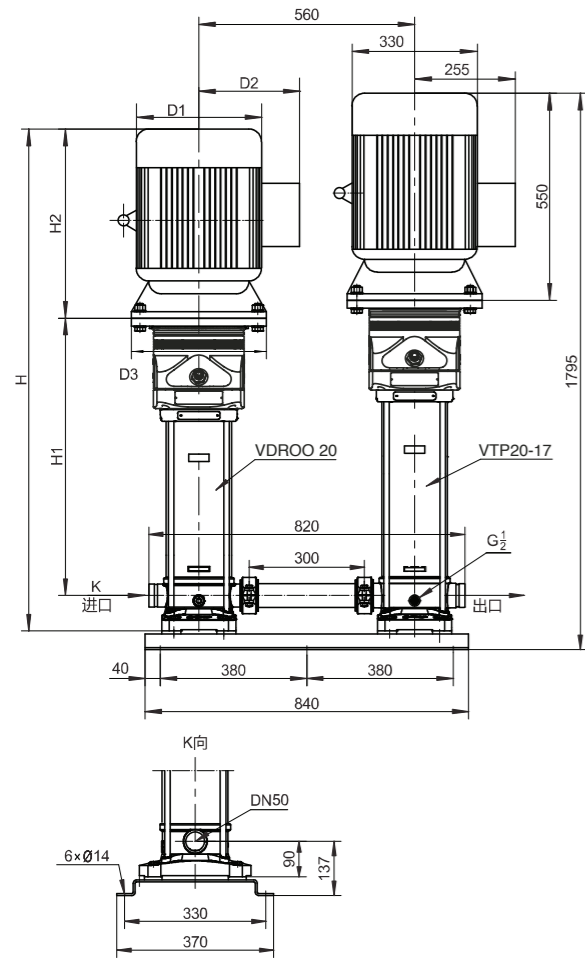

Size and weight

Model	Pump and motor dimensions						Weight (kg)
	H1	H2	H	D1	D2	D3	
VTP20-1	297	245	632	170	142	140	259
VTP20-2	307	290	687	190	155	145	267
VTP20-3	362	355	807	230	188	160	285
VTP20-4	485	390	965	260	208	200	307
VTP20-5	530	390	1010	260	208	200	309
VTP20-6	575	390	1055	260	208	200	318
VTP20-7	620	390	1100	330	208	200	319
VTP20-8	695	500	1285	330	255	350	386
VTP20-10	785	500	1375	330	255	350	389
VTP20-12	875	500	1465	330	255	350	407
VTP20-14	965	500	1555	330	255	350	410
VTP20-17	1100	550	1740	330	255	350	431

Performance table

Model	Motor (kW)	Q (m³/h)	H (m)												
			0	10	12	14	16	18	20	22	24	26	28	29	
VTP20-1	1.1+18.5		257.3	240.5	237.3	233	228.5	223	215.5	205	191.5	179	165	152	
VTP20-2	2.2+18.5		271.2	253.5	250	245.5	241	236	228	217	202.5	188	173	159.5	
VTP20-3	4+18.5		285.5	267.5	264	259	254	248	240	228	213	198	182	168.5	
VTP20-4	5.5+18.5		299.5	280.5	276	271	266	260.5	252	240	223.5	207	190	176.5	
VTP20-5	5.5+18.5		313.5	294	290	285	279	272	263	250	233	217	199	185	
VTP20-6	7.5+18.5		328	307	303	298	292	285	275	261	244	228	209	193	
VTP20-7	7.5+18.5		342	320.5	316	311	305	297	287	273	255	238	218	202.5	
VTP20-8	11+18.5		357	334	330	324	318	310	300	285	266	247	227	211	
VTP20-10	11+18.5		385	361	357	351	344	335	324	308	288	267	245	228	
VTP20-12	15+18.5		415	388	383	377	370	361	348	332	309	287	263	245	
VTP20-14	15+18.5		444	415	410	404	396	386	373	355	331	307	281	262	
VTP20-17	18.5+18.5		488	456	450	443	435	424	410	390	364	338	311	292	

Performance curve ISO9906 Annex A 2950rpm

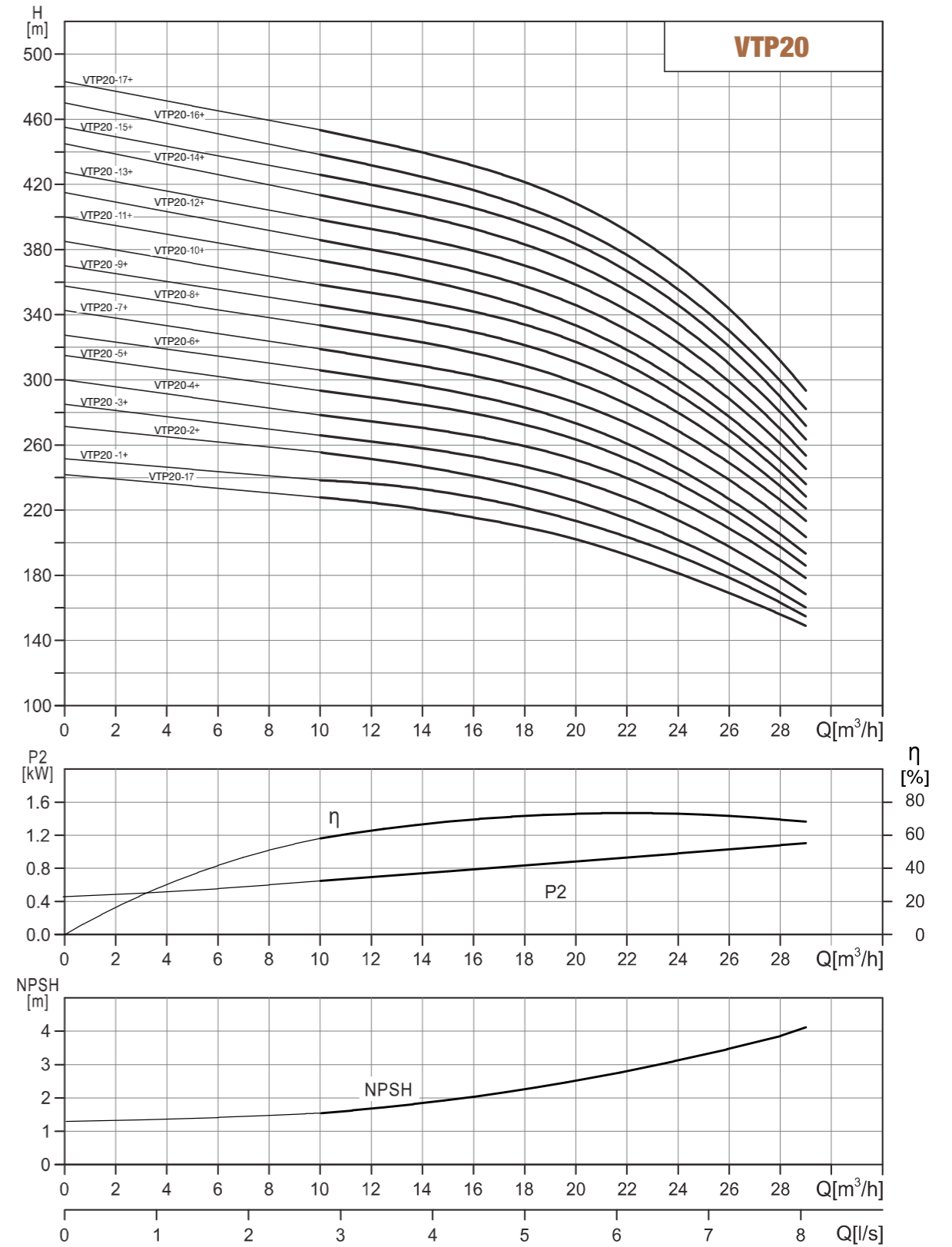

VTPS32

Installation sketch

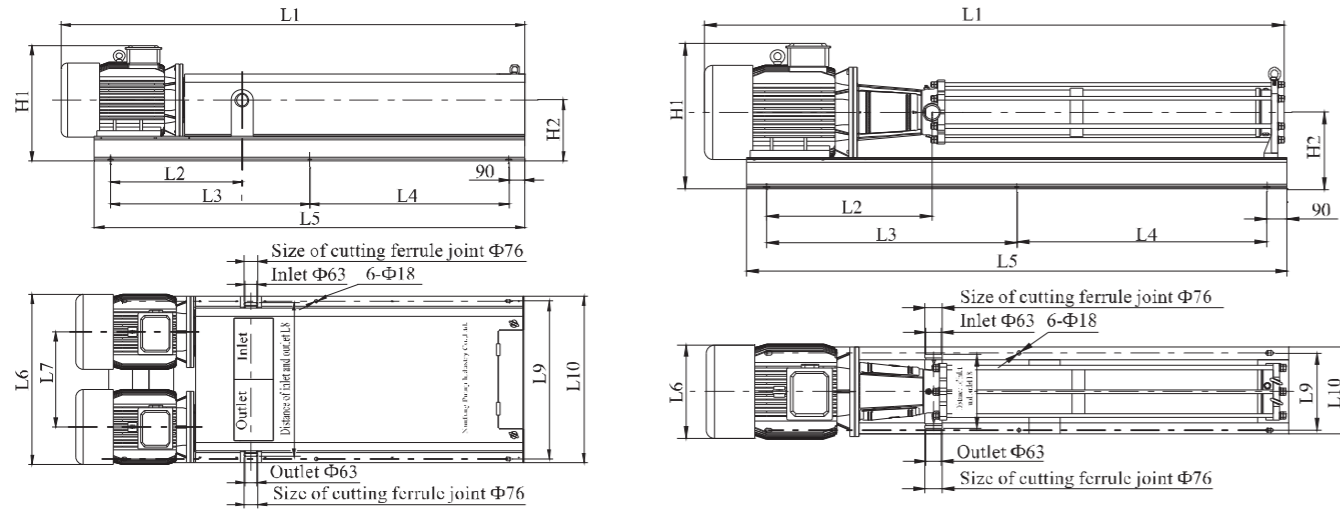

Size and weight

Model	Size (m m)												Weight (kg)
	L1	L2	L3	L4	L5	L6	L7	L8	L9	L10	H1	H2	
VTPS32-17	2446	734	1040	1040	2260	420		330	340	385	645	340	485
VTPS32-18	2516	734	1075	1075	2330	420		330	340	385	645	340	490
VTPS32-19	2586	734	1110	1110	2400	420		330	340	385	645	340	500
VTPS32-10x2	1856	653	755	755	1689	816	466	796	745	786	550	286	620
VTPS32-11x2	1956	658	792	792	1764	870	491	821	805	846	575	306	695
VTPS32-12x2	2026	658	827	827	1834	870	491	821	805	846	575	306	705
VTPS32-13x2	2166	734	900	900	1980	946	530	860	880	925	645	340	850
VTPS32-14x2	2236	734	935	935	2050	946	530	860	880	925	645	340	860
VTPS32-15x2	2306	734	970	970	2120	946	530	860	880	925	645	340	870
VTPS32-16x2	2376	734	1005	1005	2190	946	530	860	880	925	645	340	880
VTPS32-17x2	2446	734	1040	1040	2260	946	530	860	880	925	645	340	945
VTPS32-18x2	2516	734	1075	1075	2330	946	530	860	880	925	645	340	955
VTPS32-19x2	2586	734	1110	1110	2400	946	530	860	880	925	645	340	965

Performance table

Model	Driving (kw)	Q (m ³ /h)	16	20	24	28	32	36	40
VTPS32-17	37	H (m)	310	295	279	262	240	210	175
VTPS32-18	37		328	313	296	278	255	222	186
VTPS32-19	37		346	330	312	293	270	235	197
VTPS32-10x2	18.5 x 2		364	348	329	309	276	247	202
VTPS32-11x2	22 x 2		401	382	361	339	305	272	220
VTPS32-12x2	22 x 2		437	417	394	370	334	296	242
VTPS32-13x2	30 x 2		473	452	427	401	363	321	264
VTPS32-14x2	30 x 2		510	487	460	432	392	346	287
VTPS32-15x2	30 x 2		546	521	493	463	422	371	310
VTPS32-16x2	30 x 2		583	556	526	494	452	395	331
VTPS32-17x2	37 x 2		619	591	558	525	482	420	352
VTPS32-18x2	37 x 2		656	626	591	555	512	445	374
VTPS32-19x2	37 x 2		692	660	624	586	542	469	395

Performance curve ISO9906 Annex A 2950rpm

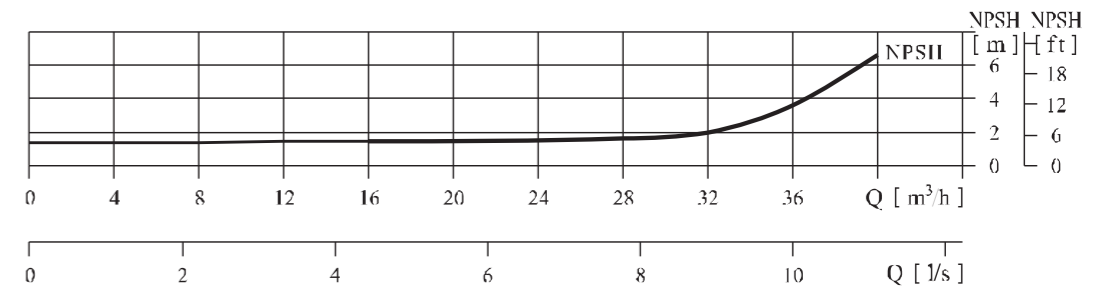
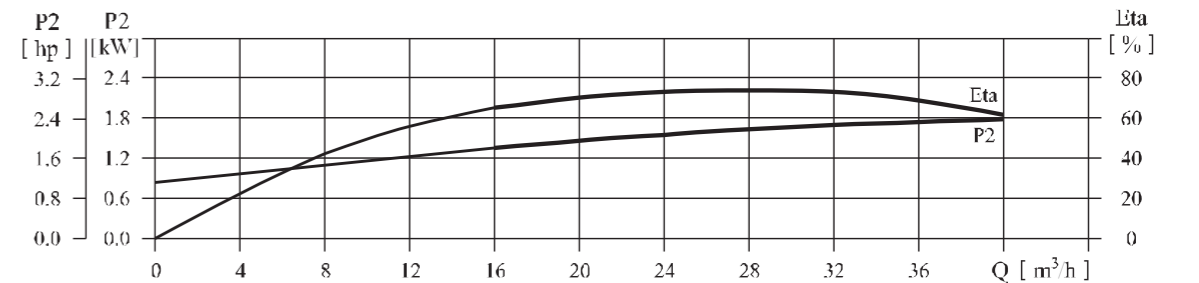
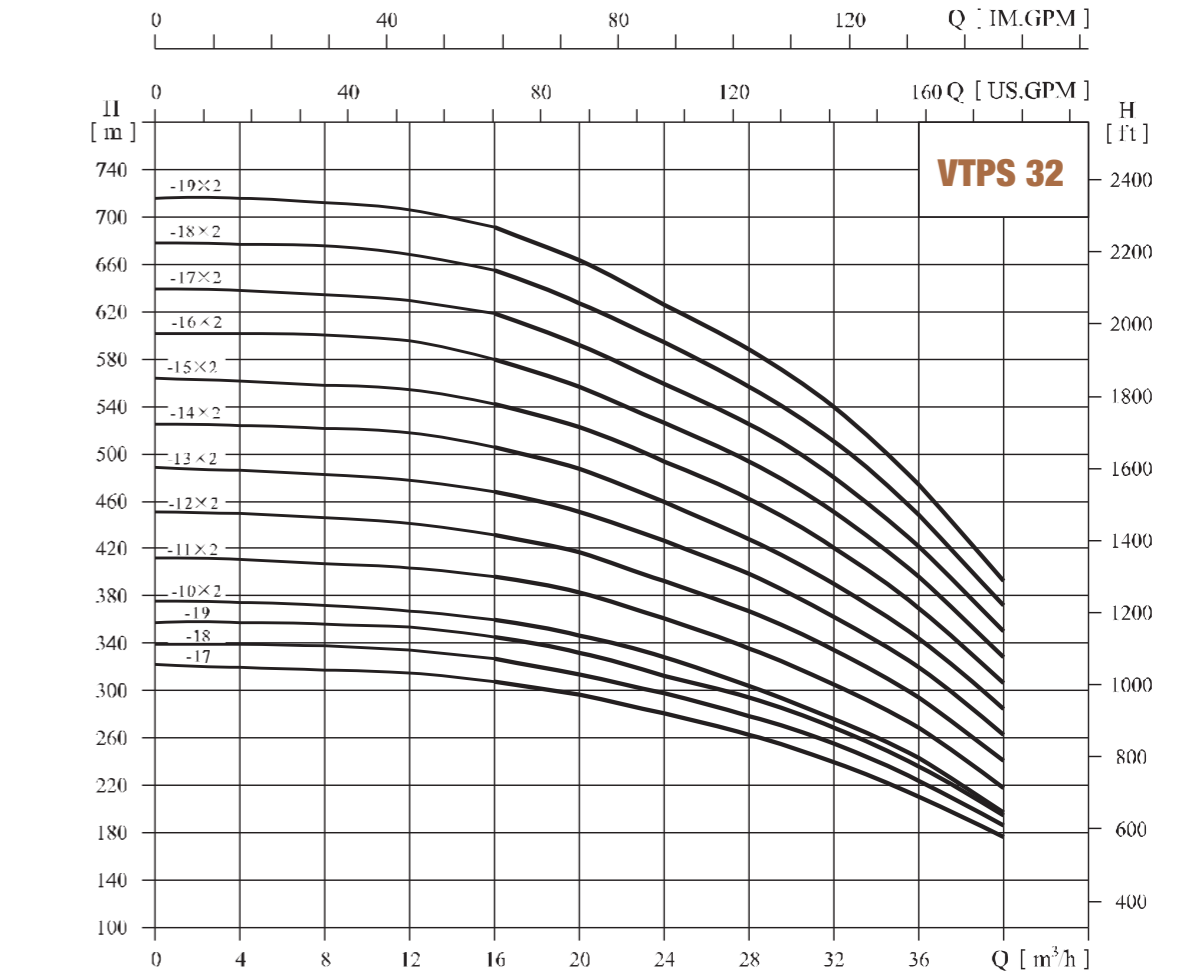

VTPS42

Installation sketch

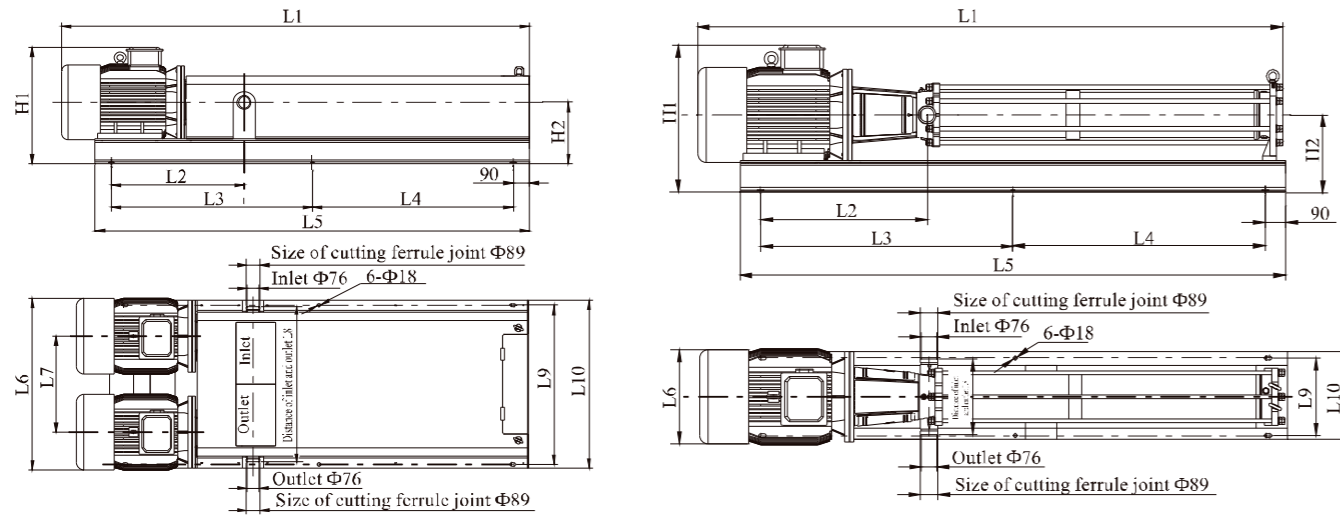

Size and weight

Model	Size (m m)												Weight (kg)
	L1	L2	L3	L4	L5	L6	L7	L8	L9	L10	H1	H2	
VTPS45-14	2525	868	1078	1078	2333	510		350	432	477	755	390	660
VTPS45-15	2605	868	1118	1118	2413	510		350	432	477	755	390	665
VTPS45-8x2	1916	744	777	777	1729	946	530	880	880	925	645	340	815
VTPS45-9x2	1996	744	817	817	1809	946	530	880	880	925	645	340	895
VTPS45-10x2	2076	744	857	857	1889	946	530	880	880	925	645	340	905
VTPS45-11x2	2195	771	910	910	1996	1020	570	920	960	1005	700	365	1040
VTPS45-12x2	2275	771	950	950	2076	1020	570	920	960	1005	700	365	1055
VTPS45-13x2	2445	868	1038	1038	2253	1130	620	970	1050	1097	755	390	1270
VTPS45-14x2	2525	868	1078	1078	2333	1130	620	970	1050	1097	755	390	1285
VTPS45-15x2	2605	868	1118	1118	2413	1130	620	970	1050	1097	755	390	1295

Performance table

Model	Driving (kw) motor	Q (m³/h)	25	30	35	40	42	45	50	55
VTPS45-14	55	H (m)	336	327	313	298	289	275	253	222
VTPS45-15	55		360	350	337	319	310	295	271	241
VTPS45-8x2	30 x 2		380	373	357	337	324	312	286	252
VTPS45-9x2	37 x 2		428	416	400	377	366	350	320	282
VTPS45-10x2	37 x 2		476	461	442	418	408	391	358	317
VTPS45-11x2	45 x 2		526	513	490	462	450	430	397	348
VTPS45-12x2	45 x 2		576	560	536	510	494	472	434	380
VTPS45-13x2	55 x 2		624	607	581	553	536	513	470	412
VTPS45-14x2	55 x 2		672	652	625	595	578	555	507	443
VTPS45-15x2	55 x 2		718	697	670	638	620	597	548	475

Performance curve ISO9906 Annex A 2950rpm

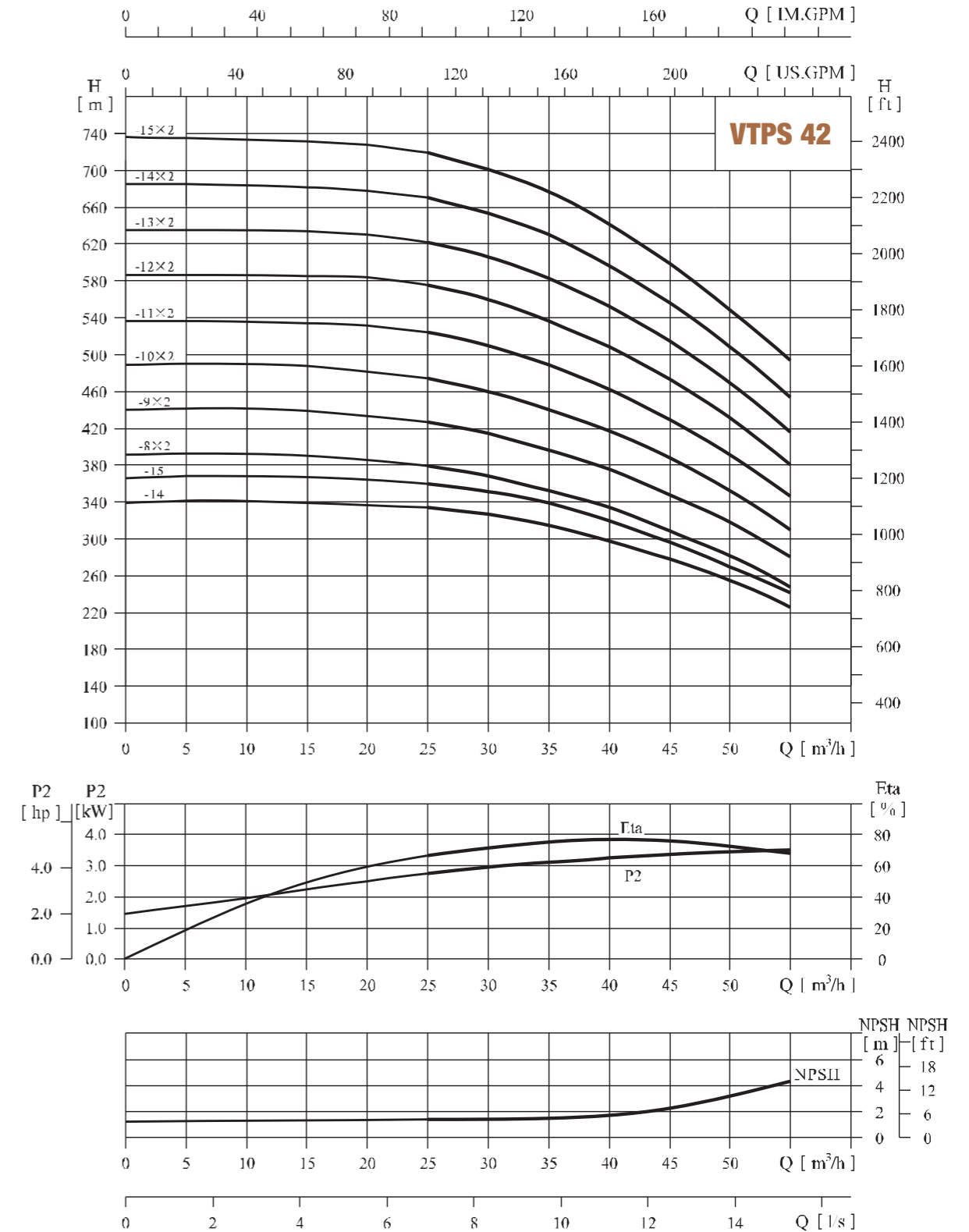

VTPM

Installation sketch

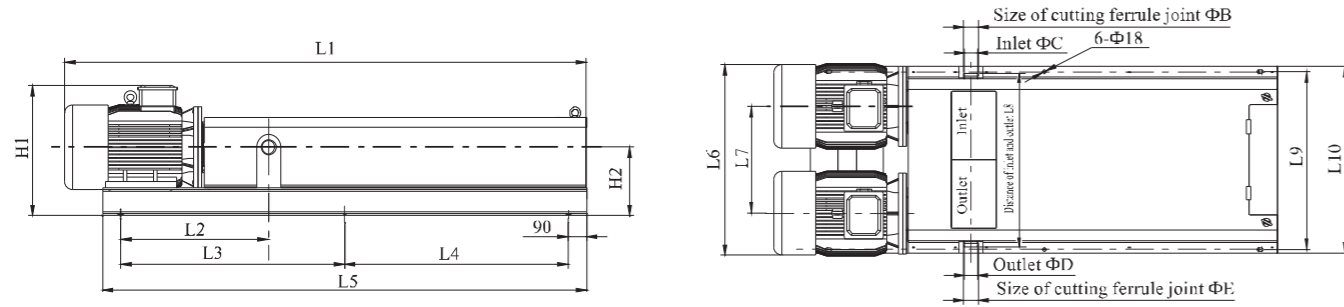

Size and weight

Model	Size (m m)																Weight (kg)
	L1	L2	L3	L4	L5	L6	L7	L8	L9	L10	H1	H2	B	C	D	E	
VTPM 20 - 18/18	2516	734	1075	1075	2330	946	530	860	880	925	645	340	76	63	63	76	955
VTPM 45 - 15/15	2515	771	1070	1070	2316	1020	570	920	960	1005	700	365	89	76	76	89	1095

Performance table

Model	Driving motor (kw)	Q (m³/h)	5	10	15	20	22	25	30	35	40	42	45
VTPM 20 - 18/18	30 x 2	H (m)	678	669	659	626	612						
VTPM 45 - 15/15	52 x 2					725	722	718	697	670	638	620	597

Performance curve ISO9906 Annex A 2950rpm

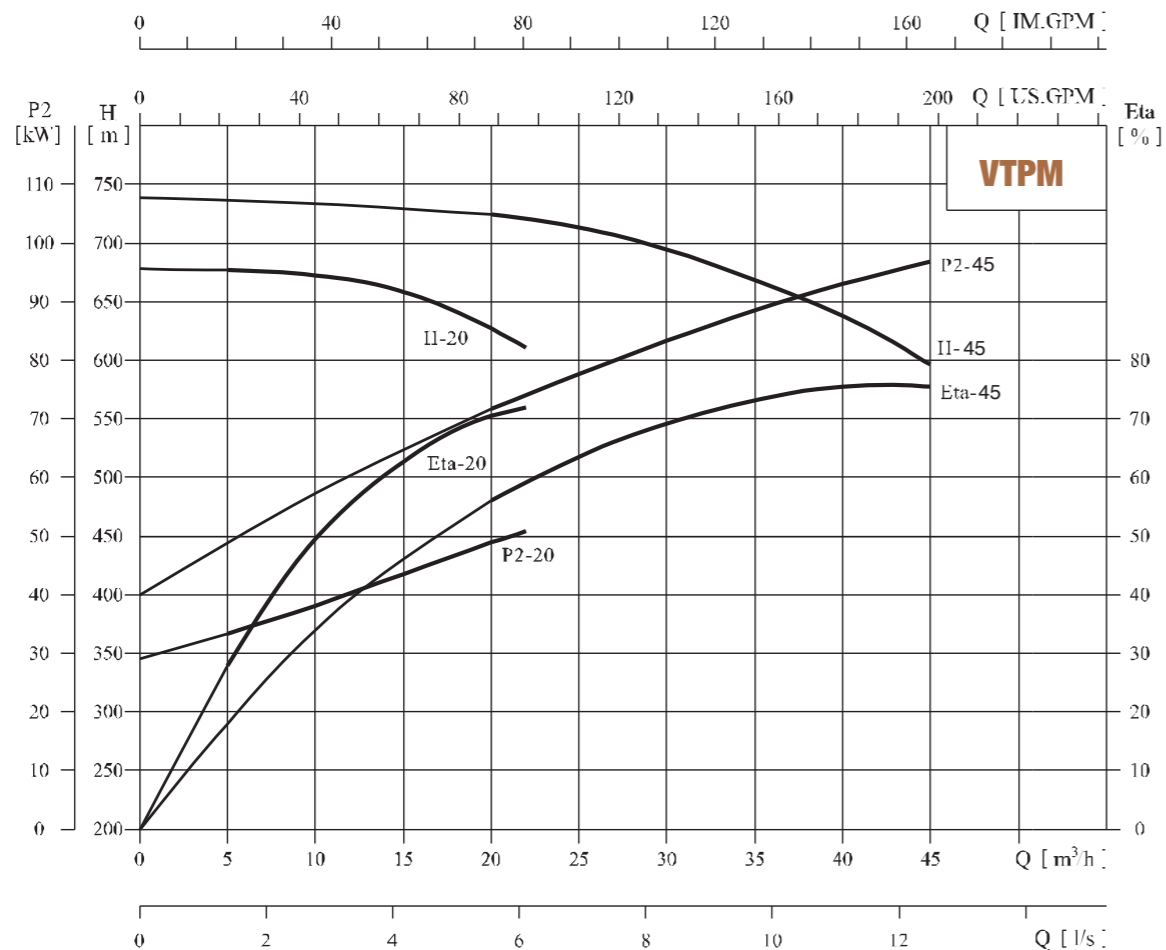

Notes

hydroo®

Be pumping partners

HYDROO
Pump Industries SL

Carrer La Banyeta Nova, 11
Polígon Industrial La Banyeta
17843 Palol de Revardit
Catalonia. Spain
Tel. +34 972 394 654
E-mail: info@hydroo.com
www.hydroo.com

201949-CTL-VTP-EN
subject to amendments

