

hydroo[®]

SDROO SERIES

SX, SN, SD

**Submersible
borehole pump
50Hz**





PRESENTATION

HYDROO has set up a worldwide distribution network with key partners and is providing value to pump engineers and end users. We have an extensive pump portfolio with high-end solutions for many applications, including water-supply booster sets, fire-fighting equipment, borehole, HVAC, drainage and sewage, utilities, irrigation, desalination and RO equipment, and OEM integration, among many others. We provide solutions for all markets for 50 Hz and 60 Hz, including customized versions.

HYDROO has a factory in Palol de Revardit (Catalonia- Spain). It's been sized to guarantee our reliable, long-term, personalized manner and offer the best service to all our customers. We provide a wide range of products in an extremely short delivery time, thanks to our Lean manufacturing processes and our qualified professional and enthusiastic team.

Our commitment to ethics and legislation in relation to third parties is compiled in a public document of principles. The document has been agreed upon by the entire Hydroo team and its implementation is being coordinated by a committee to ensure the compliance and strengthening of the corporate culture in the whole company.

The expansion of Hydroo is based on excellence in operations and a successful business relationship with partners. Therefore, we face a strong growth in the target market. We are fully audited by SGS for ISO9001 and ISO14000 standards annually.

At HYDROO, we are committed to providing excellent service to our valued pump partners.

SX, SN, SD

Stainless steel submersible pumps

Applications

Water supply from deep wells and dams
Irrigation
Sprinkling and boosting
Fire fighting applications
Washing systems
Mining

Description

Multistage submersible pumps fully made in stainless steel. Built-in non-return valve included. Made by stamping and welding or made of micro-precision casted stainless steel. Motors according to NEMA standards.

Performance range

Capacity: Q up to 540 m³/h

Head: H up to 450 m

Temperature: T up to 50 °C

Speed: n 2900 rpm or 3500 rpm

Power: P up to 350 kW

Standard material

All parts are made in stainless steel. SX fully made in AISI304 SS, SN in AISI316 and SD in Duplex material.



Performance scope

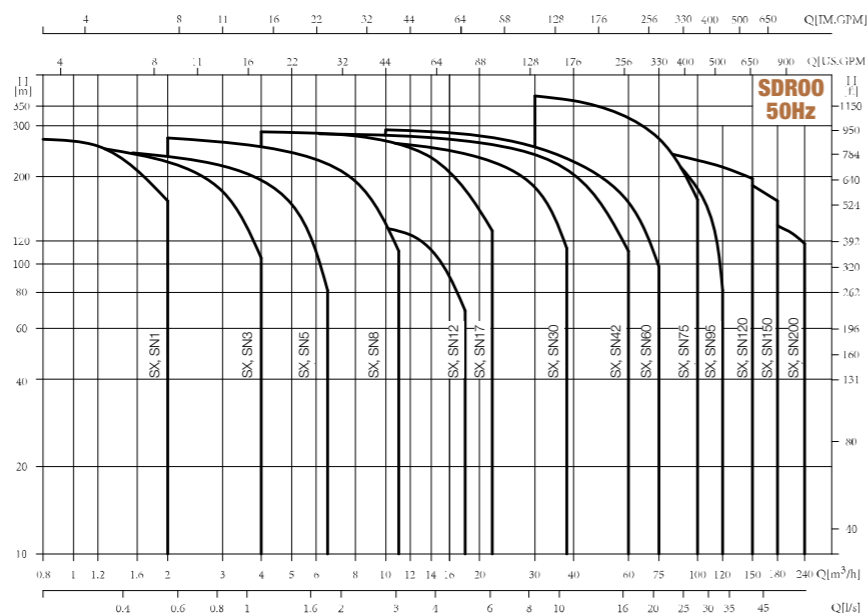

Typical applications

- Any application in the industrial, irrigation and building sector.
- Specially designed for municipal water supply from deep wells and dams or reservoirs.
- Also for direct boosting and water supply to industries, buildings, fountains or fire-fighting systems.
- Any sort of irrigation and agricultural application.
- Mining.

Operation conditions

- Clean water with suspended sand up to 100 g/m³.
- Not admitted fibres.
- Immersion depth up to 300 m.
- Maximum working pressure 38 bar.– Horizontal installation suitable with a minimum inclination of 5°.
- Liquid pH 6.5 - 9.5.

– For horizontal installations and open wells or reservoirs it is recommended the use of a cooling shroud, available on request.

– Special version made in Duplex for corrosive liquids, including salty water and sea water.

Curve conditions

- The curve tolerance complies with ISO9906 Annex A.
- All curves are based on the measured values of 50Hz: constant motor speed 2850r/min or 2900r/min.
- All measurements are carried out with gas-free water of temperature 20 °C. The curve is applicable to kinematical viscosity 1mm/s. In case density of the liquid conveyed by the pump is higher than that of water, it is necessary to use corresponding motor of higher output power.
- The thickened curve means the recommended performances scope.
- The performance curve includes loss caused by check valve etc.

Performance curves

- All pumps are tested before shipment according to ISO9906:2012 Grade 3B.
- Tests are carried on with clean water at 20°C and viscosity 1 mm/s.
- All pump performs MEI rates ≥0.4.

NEMA Motor

- 4" Motor.
Single phase: 0.37 kW~2.2 kW
Three phase: 0.37 kW~7.5 kW
- 6" Motor: 4 kW~37 kW
- 8" and 10" Motor:: 5.5 kW~129 kW

Product range

Description	SX, SN 1	SX, SN 3	SX, SN 5	SX, SN 8	SX, SN 12	SX, SN 17	SX, SN 30
Rate flow [m ³ /h]	1	3	5	8	12	17	30
Rate flow [l/s]	0.28	0.83	1.39	2.22	3.33	4.72	8.33
Flow range [m ³ /h]	0.2~2	0.8~4	1~6.5	2~11	3~18	4~22	5~38
Flow range [l/s]	0.06~0.56	0.22~1.1	0.28~1.8	0.56~3.1	0.83~5	1.11~6.1	1.39~10.6
Max. pressure [bar]	28	25	24	27	16	26	28
Motor power [kW]	0.37~2.2	0.37~3	0.37~4	0.75~7.5	1.5~7.5	0.55~15	1.1~22
Temp. [°C]	45	56	59	60	60	73	74
Pipe screw joint	Rp1¼	Rp1¼	Rp1½	Rp2	Rp2	Rp2½	Rp3

Description	SX, SN 42	SX, SN 60	SX, SN 75	SX, SN 95	SX, SN 120	SX, SN 150	SX, SN 200
Rate flow [m ³ /h]	42	60	75	95	120	150	200
Rate flow [l/s]	11.7	16.7	20.8	26.4	33.3	41.6	55.6
Flow range [m ³ /h]	5~60	10~75	30~100	40~120	60~150	80~180	100~240
Flow range [l/s]	1.39~16.7	2.8~20.8	8.3~27.8	11.1~33.3	16.5~41.6	22.2~50	27.8~66.7
Max. pressure [bar]	28	29	38	34	25	23	16
Motor power [kW]	1.1~37	2.2~37	7.5~75	9.2~75	11~110	9.2~110	30~110
Temp. [°C]	75	79	79	80	77	77	79
Pipe screw joint	Rp3	Rp4	Rp5	Rp5	Rp6	Rp6	Rp6

Definition of model

Stamped versions

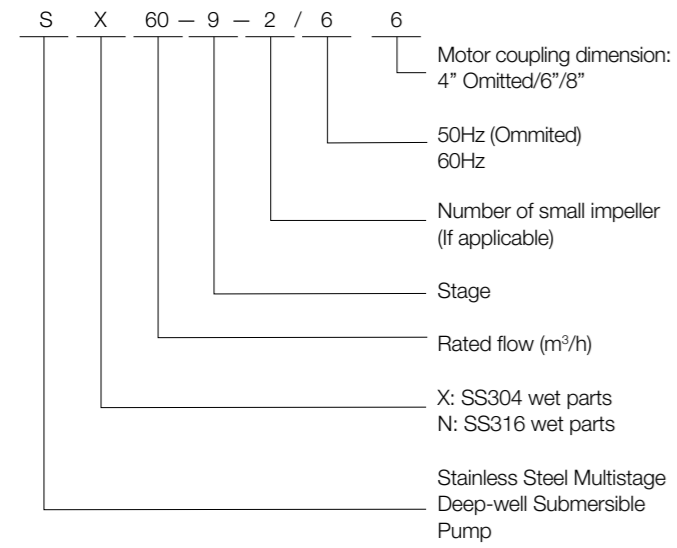

Casted version

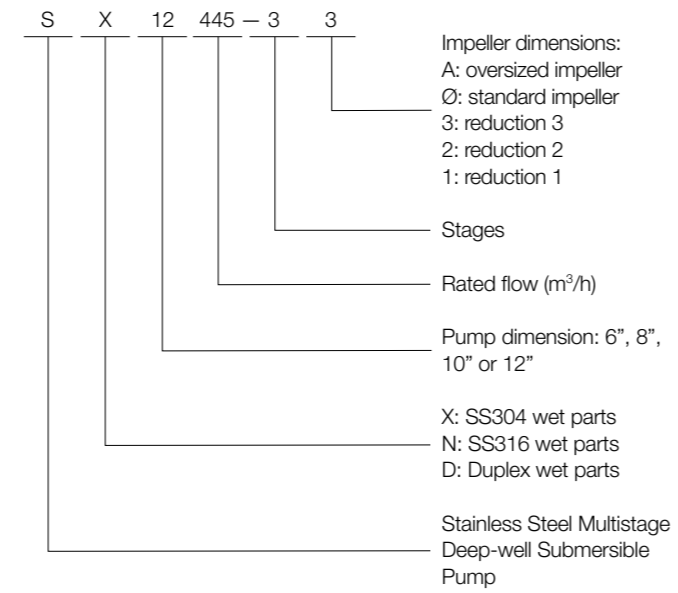

Material

N°	Name	Material	AISI
1	Discharge head	SS304/SS316	AISI304/AISI316
3	Valve cap	SS304/SS316	AISI304/AISI316
5	Discharge diffuser	SS304/SS316	AISI304/AISI316
6	Impeller nut	SS304/SS316	AISI304/AISI316
7	Impeller	SS304/SS316	AISI304/AISI316
8	Impeller cone	SS304/SS316	AISI304/AISI316
9	Diffuser	SS304/SS316	AISI304/AISI316
10	Straps	SS304/SS316	AISI304/AISI316
11	Inducer	SS304/SS316	AISI304/AISI316
12	Pump shaft	SS304/420/431	AISI304/316/420/431
13	Suction Interconnector	SS304/SS316	AISI304/AISI316
15	Neck ring	SS304/SS316	AISI304/AISI316
16	Cable guard	SS304/SS316	AISI304/AISI316
18	Submersible motor	Carbon	Carbon
21	Inlet spacer	Carbon	AISI304/AISI316
31	Connecting sleeve	SS304/SS316	AISI304/AISI316

Section drawing

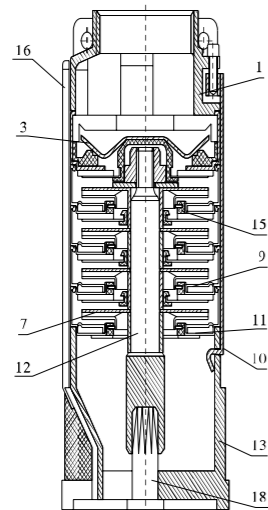

Ex: SX, SN 5

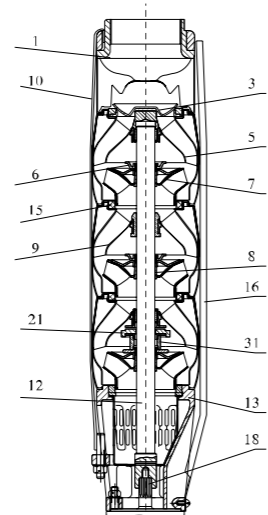

Ex: SX, SN 42

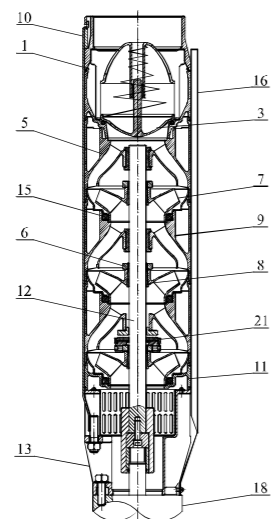

Ex: SX, SN 95

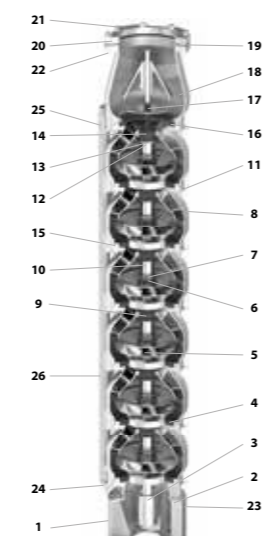

Ex: SX, SN, SD 6-8-10-12

SX, SN 1

Performance curve ISO9906 Annex A 2850rpm

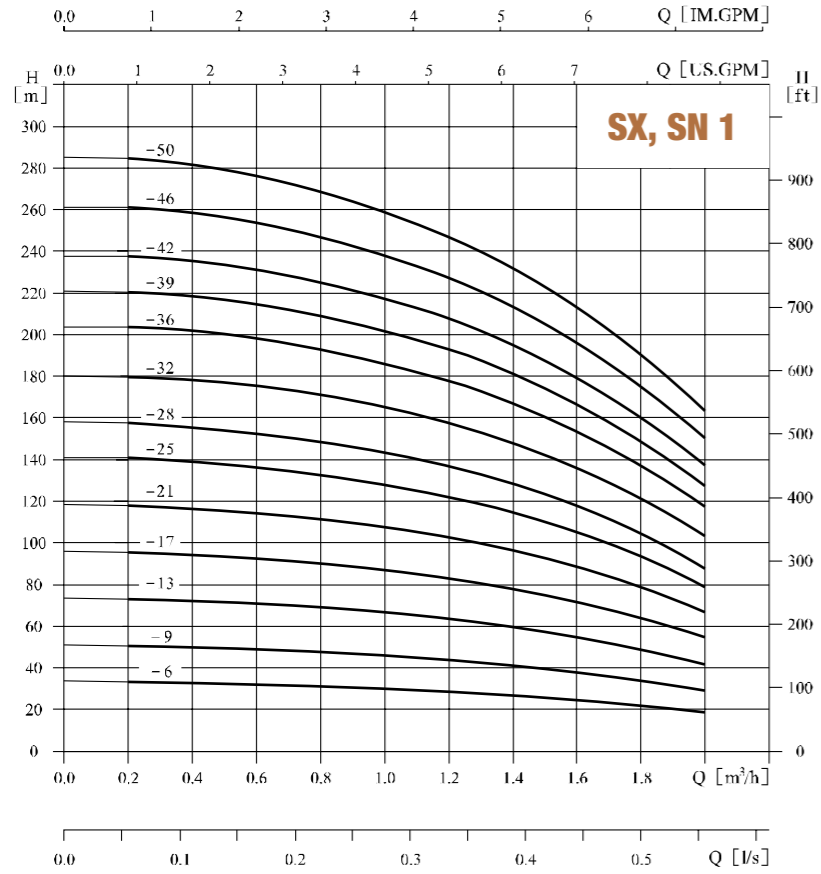

Installation sketch

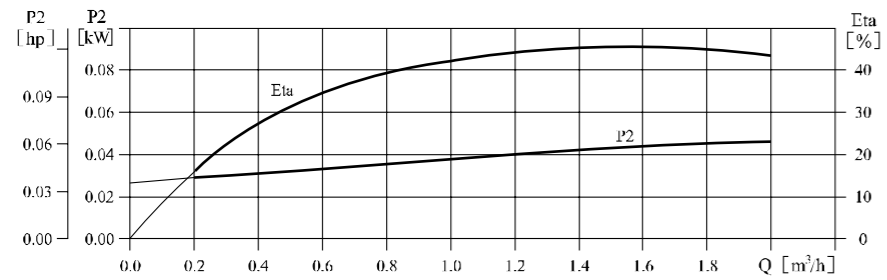
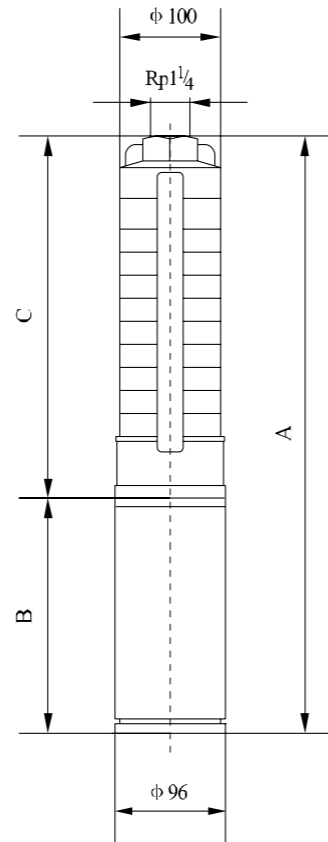

Performance table

Model	Driving motor		Q (m³/h)	Q											
	(kW)	(hp)		0.2	0.4	0.6	0.8	1.0	1.2	1.4	1.6	1.8	2.0		
SX, SN1-6	0.37	0.5	H (m)	33.5	33	32	31	30	29	27	25	22	19		
SX, SN1-9	0.37	0.5		51	50	49	48	46	44	41	38	34	29		
SX, SN1-13	0.55	0.75		73	72	71	69	67	64	60	55	49	42		
SX, SN1-17	0.75	1		96	95	92	90	87	84	78	71	64	55		
SX, SN1-21	1.1	1.5		119	118	115	112	108	103	97	89	80	69		
SX, SN1-25	1.1	1.5		141	140	137	134	129	123	116	106	95	82		
SX, SN1-28	1.5	2		158	157	153	150	145	138	130	119	107	92		
SX, SN1-32	1.5	2		180	179	175	171	165	158	148	136	122	105		
SX, SN1-36	1.5	2		203	202	197	192	186	178	167	153	137	118		
SX, SN1-39	2.2	3		221	219	214	209	202	193	181	166	149	128		
SX, SN1-42	2.2	3		238	236	230	225	217	208	195	179	160	137		
SX, SN1-46	2.2	3		260	258	252	246	238	227	213	196	176	151		
SX, SN1-50	2.2	3		284	282	276	269	260	248	233	214	192	165		

Size and weight

Model	Size (mm)			Weight (kg)
	A	B	C	
SX, SN1-6	667	370	297	12
SX, SN1-9	730	370	360	13
SX, SN1-13	S24	380	444	15
SX, SN1-17	928	400	528	17
SX, SN1-21	1052	440	612	19
SX, SN1-25	1136	440	696	20
SX, SN1-28	1229	470	759	23
SX, SN1-32	1313	470	843	24
SX, SN1-36	1397	470	927	25
SX, SN1-39	1500	510	990	29
SX, SN1-42	1563	510	1053	30
SX, SN1-46	1647	510	1137	31
SX, SN1-50	1731	510	1221	32

SX, SN 3

Performance curve ISO9906 Annex A 2850rpm

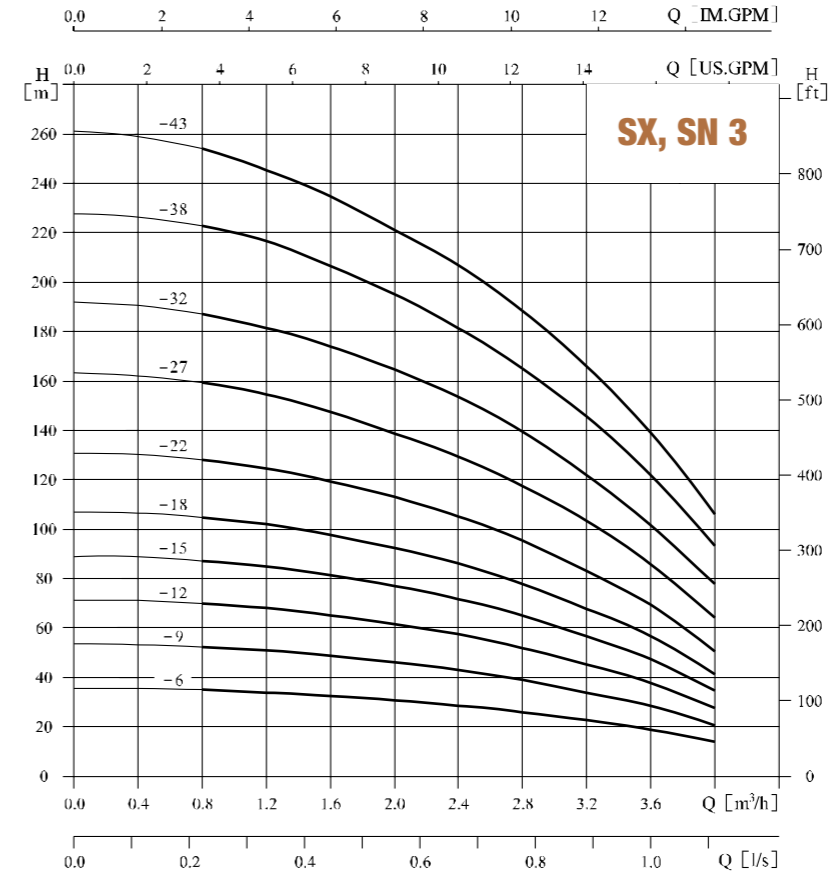

Installation sketch

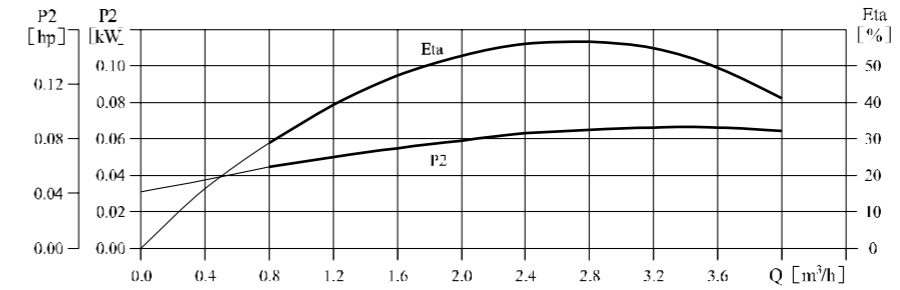
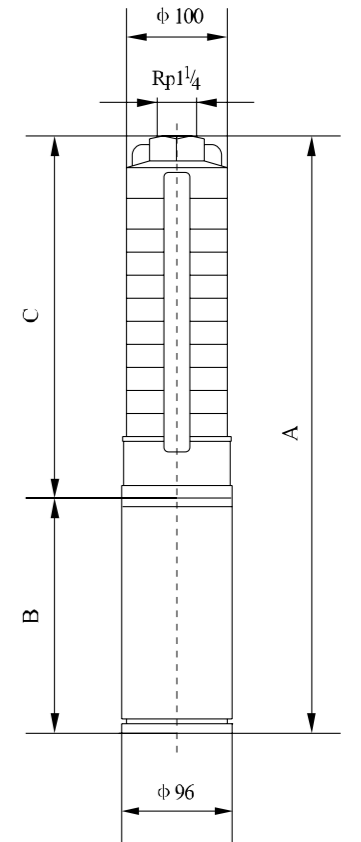

Performance table

Model	Driving motor		Q (m³/h)	Q									
	(kW)	(hp)		0.8	1.2	1.6	2.0	2.4	2.8	3.0	3.2	3.6	4.0
SX, SN3-6	0.37	0.5	H (m)	36	34	32	30	28	26	24	23	18	13
SX, SN3-9	0.55	0.75		53	51	48	45	42	38	36	33	27	20
SX, SN3-12	0.75	1		70	68	64	61	57	52	49	44	37	27
SX, SN3-15	1.1	1.5		87	85	81	77	72	65	61	56	47	34
SX, SN3-18	1.1	1.5		105	103	97	92	87	78	74	68	57	42
SX, SN3-22	1.5	2		130	126	120	113	106	96	91	84	70	53
SX, SN3-27	2.2	3		159	154	146	138	130	118	111	104	87	66
SX, SN3-32	2.2	3		189	183	173	163	154	140	131	122	102	79
SX, SN3-38	3.0	4		224	217	205	194	183	168	157	146	122	94
SX, SN3-43	3.0	4		254	246	233	220	207	190	178	166	139	107

Size and weight

Model	Size (mm)			Weight (kg)
	A	B	C	
SX, SN3-6	667	370	297	12
SX, SN3-9	740	380	360	13
SX, SN3-12	823	400	423	16
SX, SN3-15	926	440	486	18
SX, SN3-18	999	440	549	19
SX, SN3-22	1103	470	633	22
SX, SN3-27	1248	510	738	27
SX, SN3-32	1353	510	843	28
SX, SN3-38	1589	620	969	31
SX, SN3-43	1694	620	1074	32

SX, SN 5

Performance curve ISO9906 Annex A 2850rpm

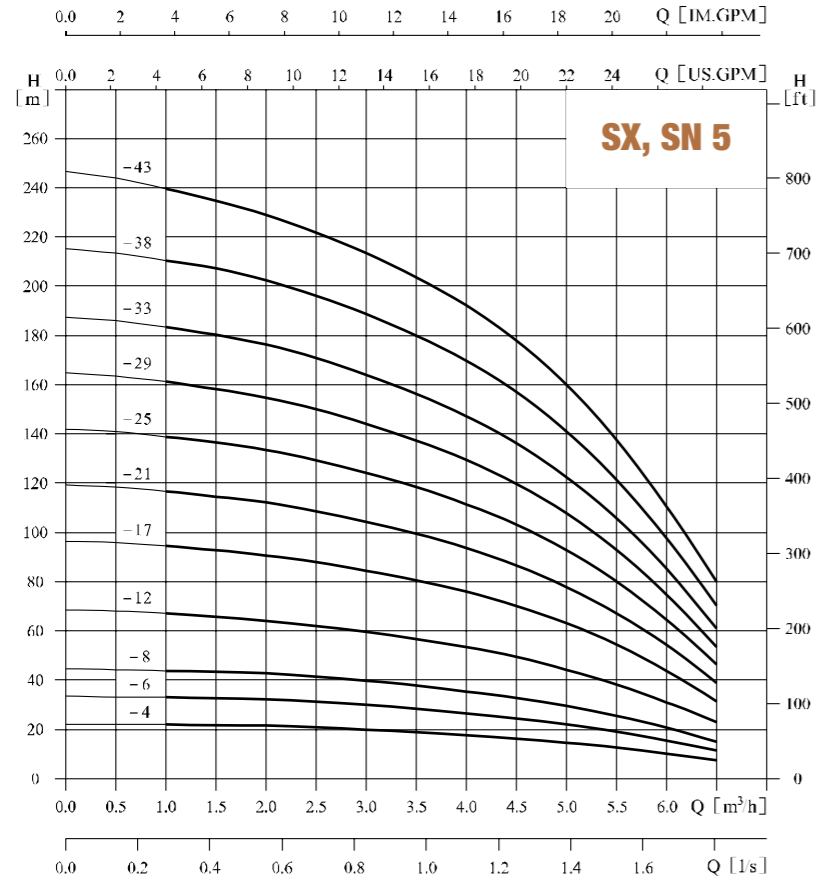

Installation sketch

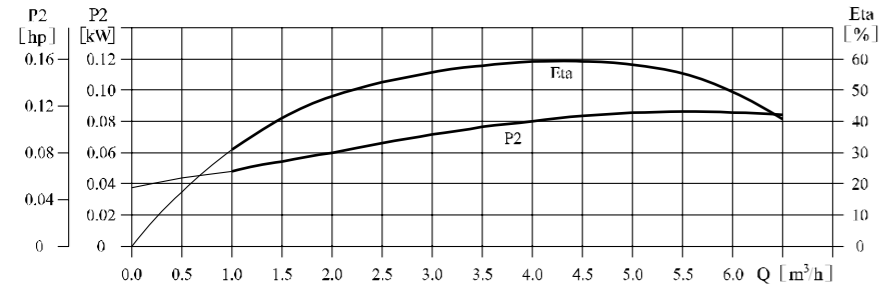
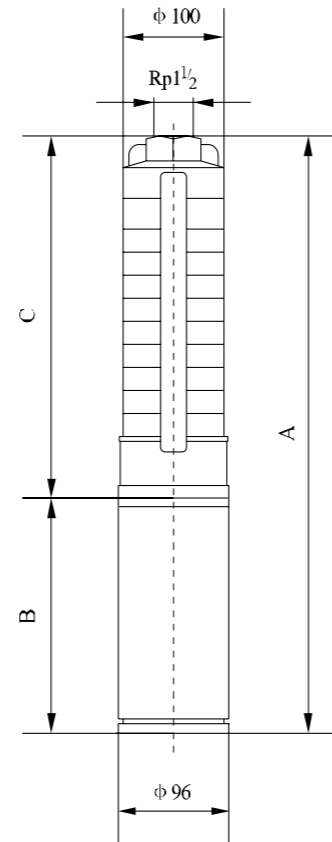

Performance table

Model	Driving motor		Q (m³/h)	H (m)										
	(kW)	(hp)		1.0	2.0	3.0	3.5	4.0	4.5	5.0	5.5	6.0	6.5	
SX, SN5-4	0.37	0.5		21	20.5	20	19	18	17	15	13	10	6	
SX, SN5-6	0.55	0.75		32	31	30	28	27	25	22	19	15	11	
SX, SN5-8	0.75	1		43	42	40	36	36	33	30	25	20	15	
SX, SN5-12	1.1	1.5		66	63	59	57	54	50	45	38	30	23	
SX, SN5-17	1.5	2		95	91	84	80	76	71	64	54	43	32	
SX, SN5-21	2.2	3		117	112	104	99	94	87	79	67	53	39	
SX, SN5-25	2.2	3		139	134	124	118	112	104	94	80	64	47	
SX, SN5-29	3.0	4		161	155	144	137	130	120	108	92	74	55	
SX, SN5-33	3.0	4		183	177	163	156	148	137	123	105	84	62	
SX, SN5-38	4.0	5.5		211	203	188	178	170	158	142	121	97	71	
SX, SN5-43	4.0	5.5		239	230	213	203	193	179	161	137	109	81	

Size and weight

Model	Size (mm)			Weight (kg)
	A	B	C	
SX, SN5-4	625	370	255	12
SX, SN5-6	677	380	297	13
SX, SN5-8	739	400	339	15
SX, SN5-12	863	440	423	17
SX, SN5-17	998	470	528	21
SX, SN5-21	1122	510	612	26
SX, SN5-25	1206	510	696	27
SX, SN5-29	1400	620	780	29
SX, SN5-33	1484	620	864	30
SX, SN5-38	1719	750	969	33
SX, SN5-43	1824	750	1074	35

SX, SN 8

Performance curve ISO9906 Annex A 2850rpm

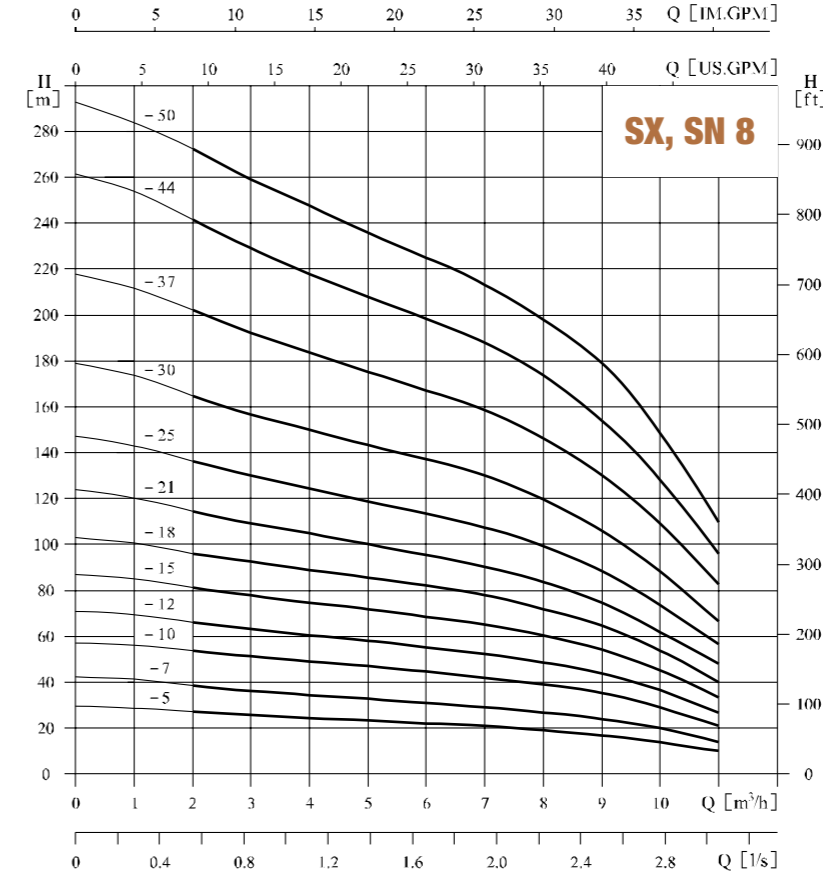

Installation sketch

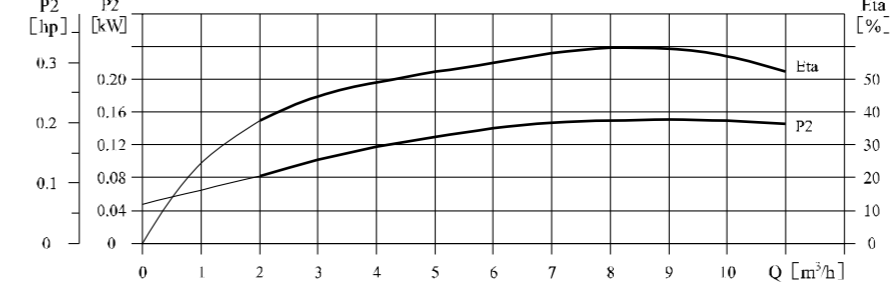
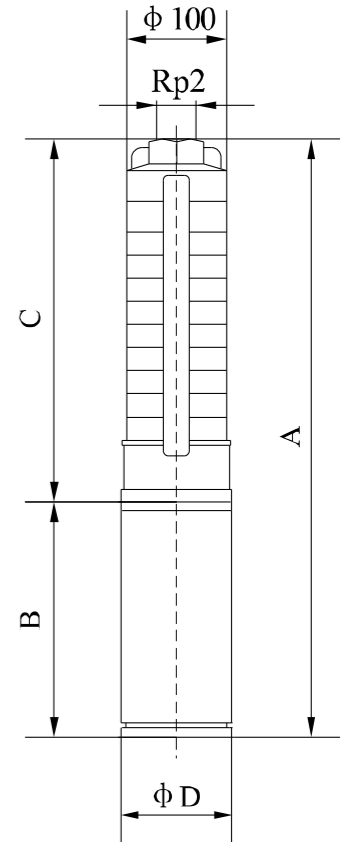

Performance table

Model	Driving motor		Q (m³/h)	H (m)										
	(kW)	(hp)		2	3	4	5	6	7	8	9	10	11	
SX, SN8-5	0.75	1		27	26	24	23	22	21	19	17	14	10	
SX, SN8-7	1.1	1.5		38	36	34	33	31	29	27	24	20	14	
SX, SN8-10	1.5	2		54	52	50	47	45	42	39	35	29	21	
SX, SN8-12	2.2	3		65	62	60	57	54	51	47	42	35	26	
SX, SN8-15	2.2	3		81	77	74	71	68	64	59	53	44	33	
SX, SN8-18	3.0	4		95	93	89	86	81	77	71	63	53	40	
SX, SN8-21	4.0	5.5		112	108	104	100	95	90	83	74	62	47	
SX, SN8-25	4.0	5.5		135	129	124	119	113	108	99	89	74	56	
SX, SN8-30	5.5	7.5		162	155	149	143	136	130	119	106	88	67	
SX, SN8-37	5.5	7.5		201	191	184	176	167	159	147	131	109	62	
SX, SN8-44	7.5	10		242	227	218	209	199	190	174	156	129	98	
SX, SN8-50	7.5	10		272	258	248	238	226	216	198	177	147	111	

Size and weight

Model	Size (mm)				Weight (kg)
	A	B	C	φD	
SX, SN8-5	853	400	453	96	16
SX, SN8-7	977	440	537	96	19
SX, SN8-10	1133	470	663	96	22
SX, SN8-12	1257	510	747	96	27
SX, SN8-15	1383	510	873	96	29
SX, SN8-18	1619	620	999	96	32
SX, SN8-21	1875	750	1125	96/143	35/41
SX, SN8-25	2043	750	1293	96/143	37/43
SX, SN8-30	2343	840	1503	96/143	43/51
SX, SN8-37	2637	840	1797	96/143	46/54
SX, SN8-44	3011	920	2091	96/143	55/66
SX, SN8-50	3263	920	2343	96/143	58/69

SX, SN 12

Performance curve ISO9906 Annex A 2850rpm

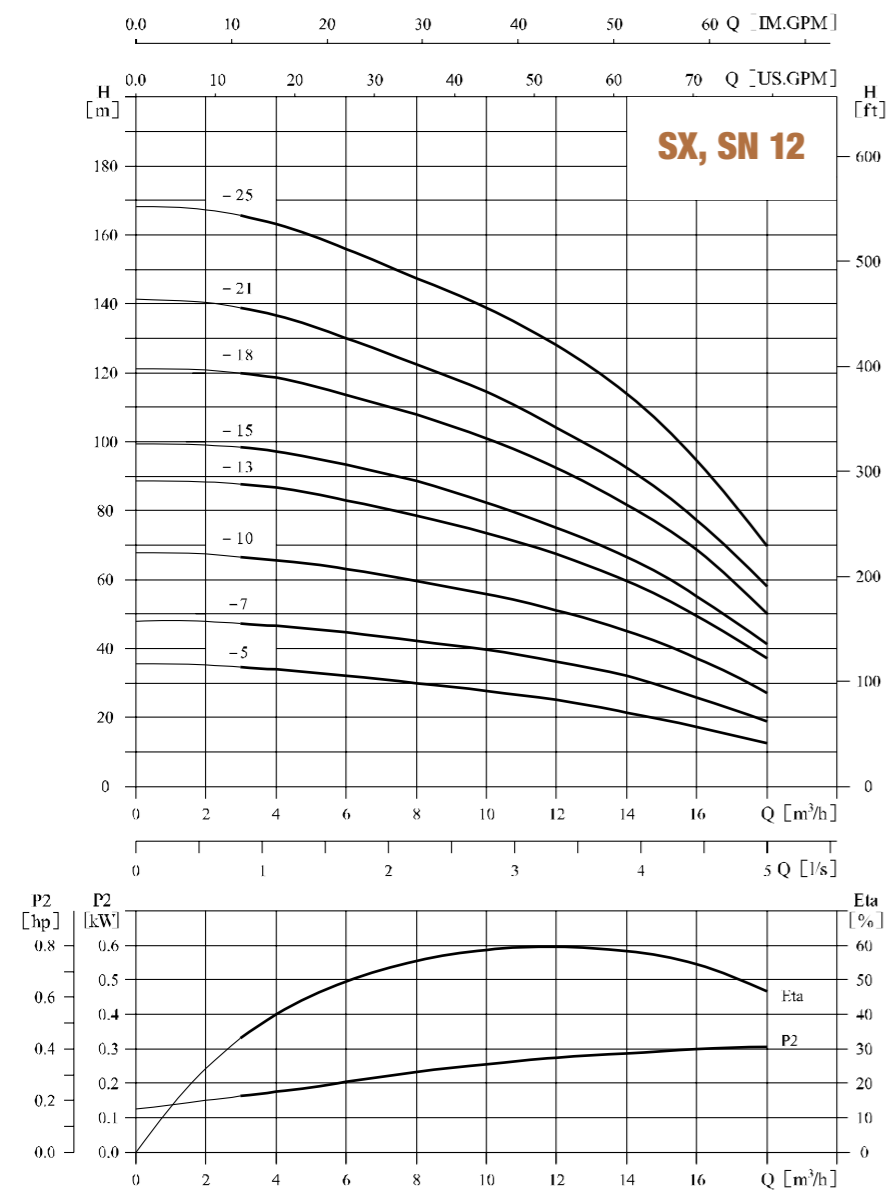

Installation sketch

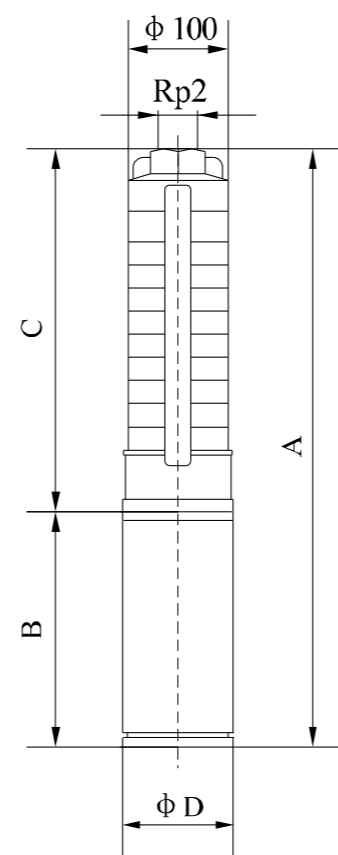

Performance table

Model	Driving motor		Q (m³/h)	H (m)								
	(kW)	(hp)		3	4	6	8	10	12	14	16	18
SX, SN12-5	1.5	2		34	33	31	29	27	25	22	18	13
SX, SN12-7	2.2	3		48	46	43	40	38	35	31	25	19
SX, SN12-10	3.0	4		67	65	62	58	55	50	45	36	27
SX, SN12-13	4.0	5.5		68	86	81	76	71	66	59	48	36
SX, SN12-15	5.5	7.5		99	97	93	88	82	76	68	55	41
SX, SN12-18	5.5	7.5		120	118	112	105	99	91	81	66	50
SX, SN12-21	7.5	10		138	136	130	123	115	106	95	77	58
SX, SN12-25	7.5	10		166	163	155	146	137	126	113	92	69

Size and weight

Model	Size (mm)				Weight (kg)
	A	B	C	ϕD	
SX, SN12-5	1005	470	535	96	21
SX, SN12-7	1175	510	665	96	26
SX, SN12-10	1480	620	860	96	30
SX, SN12-13	1837	782	1055	96/143	34/40
SX, SN12-15	2025	840	1185	96/143	38/46
SX, SN12-18	2220	840	1380	96/143	40/48
SX, SN12-21	2495	920	1575	96/143	47/58
SX, SN12-25	2755	920	1835	96/143	50/61

SX, SN 17

Performance curve ISO9906 Annex A 2850rpm

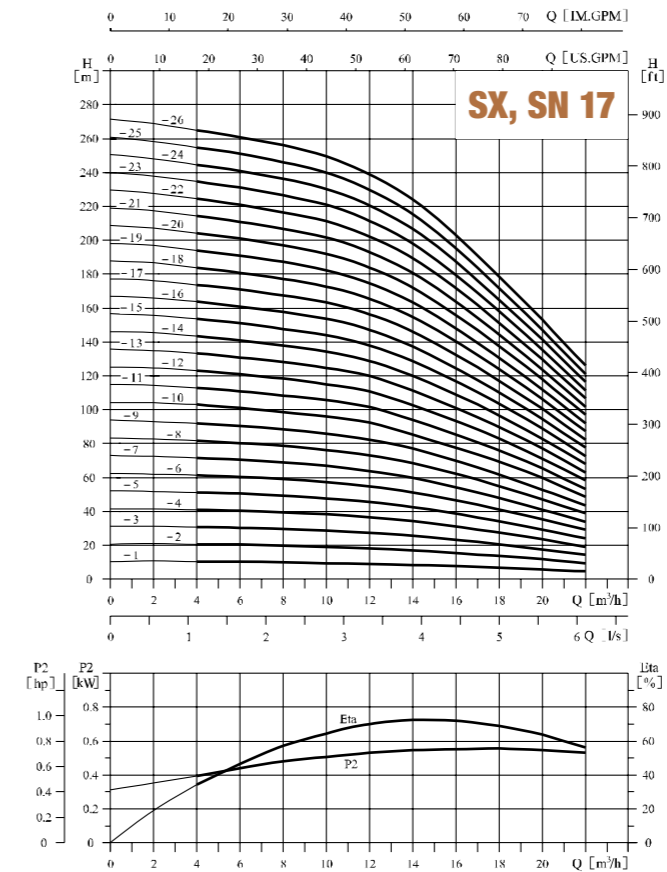

Installation sketch

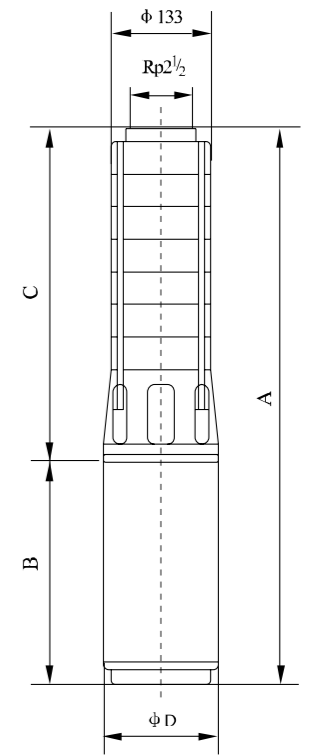

Performance table

Model	Driving motor		Q (m³/h)	H (m)											
	(kW)	(hp)		4	6	8	10	12	14	17	20	22			
SX, SN17-1	0.55	0.75		10.5	10	9.5	9	8.5	8	6.5	5	4			
SX, SN17-2	1.1	1.5		20.5	20	19.5	19	18	16	13.5	10.5	8			
SX, SN17-3	2.2	3		31	30	29.5	28.5	27	24.5	20.5	16	13			
SX, SN17-4	2.2	3		41	40	39.5	38	36.5	33.5	28	22	18			
SX, SN17-5	3.0	4		52	51	50	48	45	42	35	28	23			
SX, SN17-6	4.0	5.5		62	61	60	58	55	51	42	34	27			
SX, SN17-7	4.0	5.5		73	71	70	67	64	59	49	40	31			
SX, SN17-8	5.5	7.5		83	81	80	77	73	67	57	45	36			
SX, SN17-9	5.5	7.5		93	91	90	87	82	76	64	52	40			
SX, SN17-10	5.5	7.5		103	101	100	97	91	85	72	58	45			
SX, SN17-11	7.5	10		113	111	109	106	100	94	79	64	50			
SX, SN17-12	7.5	10		123	121	119	115	109	102	87	70	55			
SX, SN17-13	7.5	10		133	131	129	125	118	111	95	75	60			
SX, SN17-14	9.2	12.5		143	141	139	134	12B	119	102	81	65			
SX, SN17-15	9.2	12.5		153	151	14S	144	137	128	109	87	70			
SX, SN17-16	9.2	12.5		163	161	158	154	146	136	116	92	75			
SX, SN17-17	9.2	12.5		173	171	167	163	155	145	123	98	79			
SX, SN17-18	11	15		184	181	177	173	164	154	130	104	84			
SX, SN17-19	11	15		194	191	187	182	174	162	138	110	89			
SX, SN17-20	11	15		204	201	197	192	184	171	145	116	94			
SX, SN17-21	13	17.5		214	211	207	202	193	180	152	121	99			
SX, SN17-22	13	17.5		224	221	217	211	202	188	160	127	104			
SX, SN17-23	13	17.5		235	231	227	221	211	197	167	133	109			
SX, SN17-24	13	17.5		245	241	236	230	220	205	174	139	113			
SX, SN17-25	15	20		255	251	246	240	229	213	181	145	118			
SX, SN17-26	15	20		265	261	256	250	23 B	222	189	150	122			

Size and weight

Model	Size (mm)				Weight (kg)
	A	B	C	ϕD	
SX, SN17-1	708	380	328	96	17
SX, SN17-2	828	440	388	96	21
SX, SN17-3	959	510	449	96	28
SX, SN17-4	1019	510	509	96	29
SX, SN17-5	1190	620	570	96	32
SX, SN17-6	1412	782	630	96/143	35/41
SX, SN17-7	1441	782	691	96/143	36/42
SX, SN17-8	1591	S40	751	96/143	41/49
SX, SN17-9	1652	840	812	96/143	42/50
SX, SN17-10	1712	840	872	96/143	43/51
SX, SN17-11	1853	920	933	96/143	49/60
SX, SN17-12	1913	920	993	96/143	50/61
SX, SN17-13	1974	920	1054	96/143	51/62
SX, SN17-14	2027	897	1130	143	75
SX, SN17-15	2088	897	1191	143	76
SX, SN17-16	2148	897	1251	143	77
SX, SN17-17	2209	897	1312	143	78
SX, SN17-18	2314	942	1372	143	85
SX, SN17-19	2375	942	1433	143	86
SX, SN17-20	2435	942	1493	143	87
SX, SN17-21	2534	980	1554	143	95
SX, SN17-22	2594	980	1614	143	96
SX, SN17-23	2655	980	1675	143	98
SX, SN17-24	2715	980	1735	143	99
SX, SN17-25	2826	1030	1796	143	106
SX, SN17-26	2886	1030	1856	143	107

SX, SN 30

Performance curve ISO9906 Annex A 2850rpm

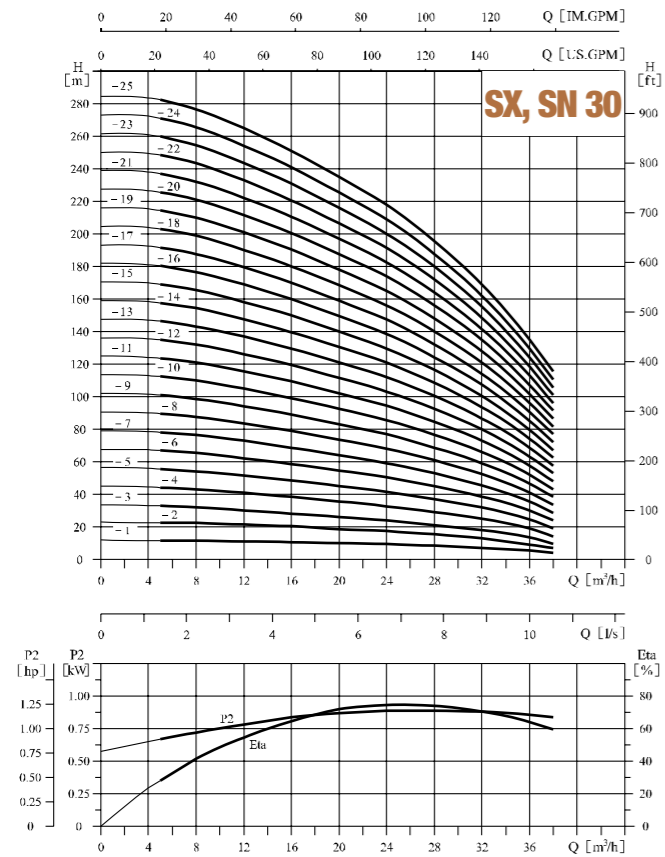

Installation sketch

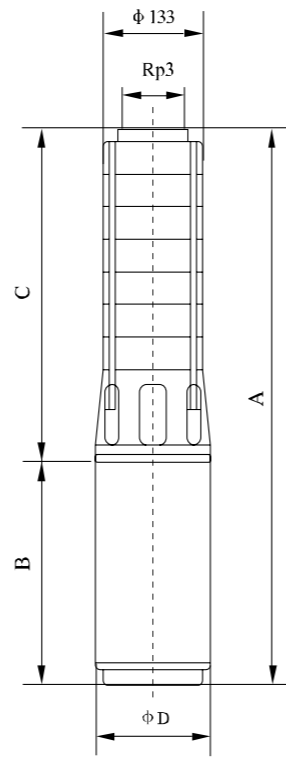

Performance table

Model	Driving motor		Q (m³/h)	H (m)											
	(kW)	(hp)		5	8	12	16	20	24	28	30	32	36	38	
SX, SN30-1	1.1	1.5	11.5	11	10.5	10	9.5	9	8	7.5	7	5.5	4.5		
SX, SN30-2	2.2	3	22.5	22	21	20	19	17.5	16	15	14	10.5	9		
SX, SN30-3	3.0	4	33.5	33	32	30	28	26	24	22	20	16	14		
SX, SN30-4	4.0	5.5	44.5	44	42	40	37	35	32	29	27	21	18		
SX, SN30-5	5.5	7.5	55.5	55	53	50	47	44	40	37	34	27	23		
SX, SN30-6	5.5	7.5	67	66	63	60	56	52	48	44	41	32	27		
SX, SN30-7	7.5	10	77	76	74	70	65	61	55	52	48	37	32		
SX, SN30-8	7.5	10	89	87	84	80	75	70	63	59	54	43	36		
SX, SN30-9	9.2	12.5	101	98	95	90	84	78	71	66	61	48	41		
SX, SN30-10	9.2	12.5	112	109	105	100	93	87	79	74	68	53	45		
SX, SN30-11	9.2	12.5	123	120	116	110	103	96	87	81	75	59	50		
SX, SN30-12	11	15	134	131	126	120	112	105	95	88	82	64	54		
SX, SN30-13	11	15	145	142	137	129	121	113	103	96	88	69	59		
SX, SN30-14	13	17.5	157	153	147	139	130	122	111	103	95	74	63		
SX, SN30-15	13	17.5	168	164	156	149	140	131	119	110	102	80	68		
SX, SN30-16	15	20	179	175	168	159	149	140	127	118	109	85	72		
SX, SN30-17	15	20	190	186	179	169	158	148	135	125	116	90	77		
SX, SN30-18	18.5	25	201	197	189	179	168	157	143	132	122	96	81		
SX, SN30-19	18.5	25	212	207	200	189	177	166	150	140	129	101	86		
SX, SN30-20	18.5	25	223	218	210	199	186	174	156	147	136	106	90		
SX, SN30-21	18.5	25	235	229	221	209	196	183	166	155	143	112	95		
SX, SN30-22	22	30	246	240	231	219	205	192	174	162	150	117	99		
SX, SN30-23	22	30	258	251	242	229	214	201	182	169	156	122	104		
SX, SN30-24	22	30	269	262	252	239	224	209	190	177	163	128	108		
SX, SN30-25	22	30	281	273	263	249	233	216	198	184	170	133	113		

Size and weight

Model	Size (mm)				Weight (kg)
	A	B	C	ΦD	
SX, SN30-1	802	440	362	96	20
SX, SN30-2	968	510	458	96	28
SX, SN30-3	1174	620	554	96	31
SX, SN30-4	1432	782	650	96/143	35/41
SX, SN30-5	1586	840	746	96/143	40/48
SX, SN30-6	1682	840	842	96/143	42/50
SX, SN30-7	1858	920	938	96/143	49/60
SX, SN30-8	1954	920	1034	96/143	51/61
SX, SN30-9	2043	897	1146	143	75
SX, SN30-10	2139	897	1242	143	77
SX, SN30-11	2235	897	1338	143	79
SX, SN30-12	2376	942	1434	143	85
SX, SN30-13	2472	942	1530	143	87
SX, SN30-14	2606	980	1626	143	96
SX, SN30-15	2702	980	1722	143	98
SX, SN30-16	2848	1030	1818	143	106
SX, SN30-17	2944	1030	1914	143	108
SX, SN30-18	3100	1090	2010	143	117
SX, SN30-19	3196	1090	2106	143	119
SX, SN30-20	3292	1090	2202	143	120
SX, SN30-21	3388	1090	2298	143	122
SX, SN30-22	3554	1160	2394	143	138
SX, SN30-23	3650	1160	2490	143	140
SX, SN30-24	3746	1160	2586	143	142
SX, SN30-25	3842	1160	2682	143	144

SX, SN 42

Performance curve ISO9906 Annex A 2850rpm

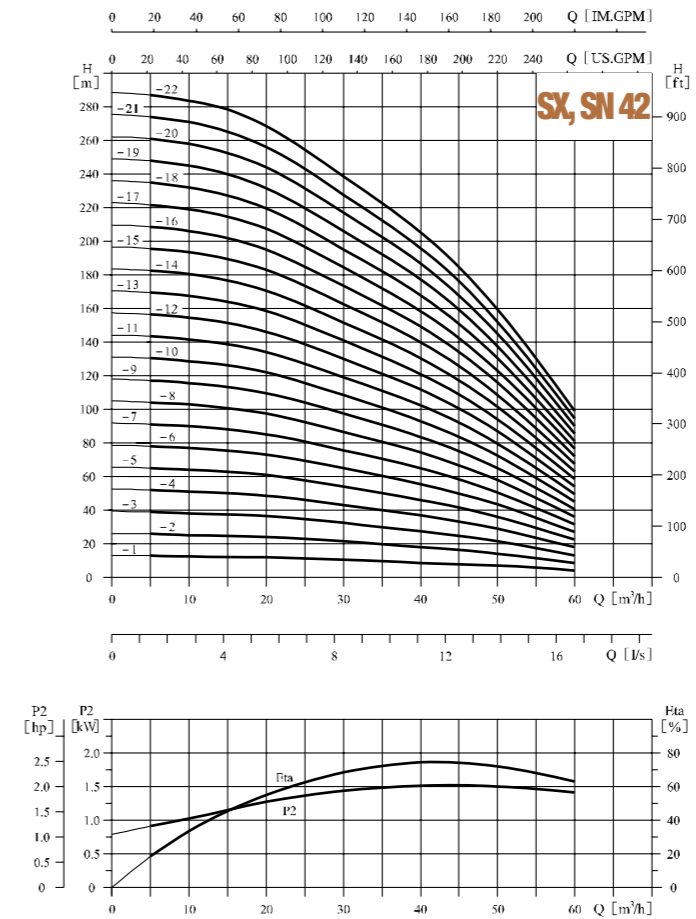

Installation sketch

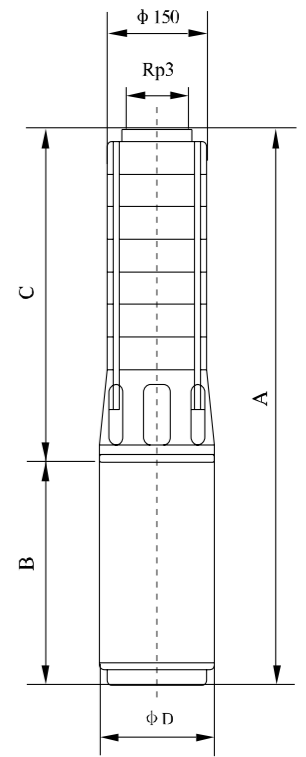

Performance table

Model	Driving motor		Q (m³/h)	H (m)											
	(kW)	(hp)		5	10	20	30	40	42	50	60				
SX, SN42-1	2.2	3	13	12.5	12	10.5	9	8.5	7	4					
SX, SN42-2	3.0	4	26	25.5	24	21.5	18.5	17	14.5	8.5					
SX, SN42-3	5.5	7.5	40	38.5	36	32.5	28	26.5	22	13					
SX, SN42-4	7.5	10	53	52	49	43	37	36	29	18					
SX, SN42-5	7.5	10	66	65	61	54	47	45	38	23					
SX, SN42-6	9.2	12.5	79	78	74	66	57	54	45	28					
SX, SN42-7	11	15	92	91	86	77	66	63	52	32					
SX, SN42-8	13	17.5	105	104	98	87	75	72	58	36					
SX, SN42-9	15	20	118	117	110	97	84	80	65	40					
SX, SN42-10	15	20	132	130	122	108	93	89	72	45					
SX, SN42-11	18.5	25	144	142	134	119	103	98	79	49					
SX, SN42-12	18.5	25	157	155	146	130	112	107	87	54					
SX, SN42-13	22	30	170	168	158	141	122	116	94	58					
SX, SN42-14	22	30	183	181	170	152	131	125	102	63					
SX, SN42-15	22	30	196	194	182	163	140	134	109	67					
SX, SN42-16	25	34	209	207	194	174	150	143	116	72					
SX, SN42-17	25	34	222	220	206	184	159	152	123	77					
SX, SN42-18	30	40	235	233	218	195	168	161	131	81					
SX, SN42-19	30	40	248	246	231	206	178	170	138	86					
SX, SN42-20	30	40	261	259	243	217	187	179	145	90					
SX, SN42-21	37	50	274	271	255	228	196	188	152	95					
SX, SN42-22	37	50	287	283	267	238	205	197	160	99					

Size and weight

Model	Size (mm)				Weight (kg)
	A	B	C	ΦD	
SX, SN42-1	888	510	378	96	29
SX, SN42-2	1111	620	491	96	33
SX, SN42-3	1444	840	604	96/143	40/48
SX, SN42-4	1637	920	717	96/M3	47/58
SX, SN42-5	1750	920	830	96/143	49/60
SX, SN42-6	1856	897	959	143	73
SX, SN42-7	2014	942	1072	143	80
SX, SN42-8	2165	980	1165	143	89
SX, SN42-9	2328	1030	1298	143	97
SX, SN42-10	2441	1030	1411	143	100
SX, SN42-11	2614	1090	1524	143	109
SX, SN42-12	2727	1090	1637	143	111
SX, SN42-13	2910	1160	1750	143	127
SX, SN42-14	3023	1160	1863	143	129
SX, SN42-15	3136	1160	1976	143	131
SX, SN42-16	3331	1242	2089	143	145
SX, SN42-17	3444	1242	2202	143	147
SX, SN42-18	3697	1382	2315	143	162
SX, SN42-19	3810	1382	2428	143	164
SX, SN42-20	3923	1362	2541	143	167
SX, SN42-21	4224	1570	2654	143	192
SX, SN42-22	4337	1570	2767	143	194

SX, SN 60

Performance curve ISO9906 Annex A 2850rpm

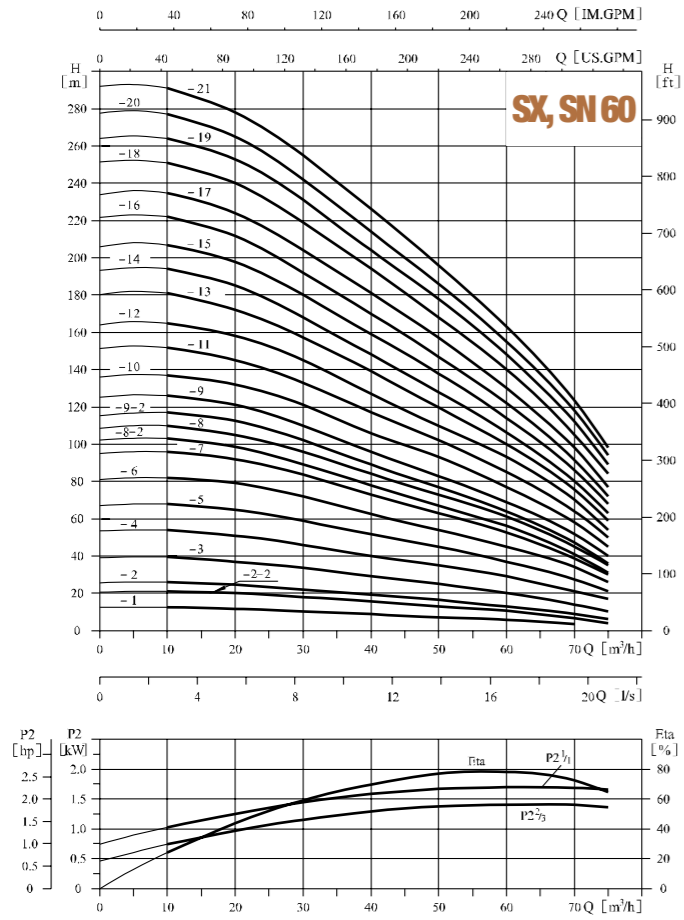

Installation sketch

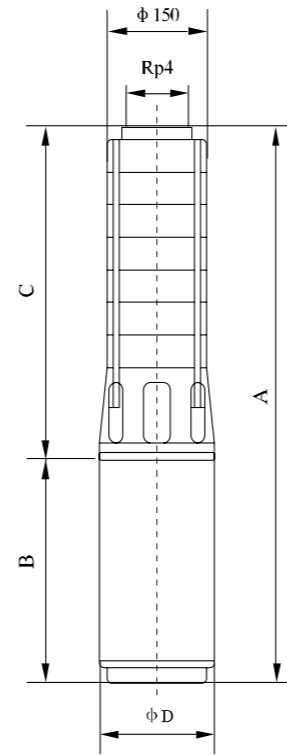

Performance table

Model	Driving motor		Q (m³/h)	H (m)							
	(kW)	(hp)		10	20	30	40	50	60	70	75
SX, SN60-1	2.2	3		12.5	12	10.5	8.5	7	6	4	—
SX, SN60-2-2	3.0	4		21	20	18	15.5	13	10.5	6.5	4
SX, SN60-2	4.0	5.5		26	24.5	22	19	16.5	12.5	9	6
SX, SN60-3	5.5	7.5		40	37	34	29	25	20	14	10
SX, SN60-4	7.5	10		54	51	46	40	35	29	21	17
SX, SN60-5	9.2	12.5		68	65	59	51	45	37	28	21
SX, SN60-6	11	15		82	79	72	62	54	45	34	26
SX, SN60-7	13	17.5		96	92	84	73	63	53	39	30
SX, SN60-8-2	13	17.5		103	99	89	78	67	56	41	31
SX, SN60-8	15	20		110	105	96	84	73	61	45	35
SX, SN60-9-2	15	20		117	112	102	89	77	64	47	36
SX, SN60-9	18.5	25		124	121	110	96	85	69	52	40
SX, SN60-10	18.5	25		137	132	121	106	93	77	58	45
SX, SN60-11	22	30		152	145	133	117	102	85	64	50
SX, SN60-12	22	30		165	158	145	127	110	93	70	54
SX, SN60-13	22	30		181	172	157	139	120	100	75	59
SX, SN60-14	25	34		194	185	168	148	128	106	80	63
SX, SN60-15	25	34		207	198	180	159	138	114	85	66
SX, SN60-16	30	40		222	212	192	170	147	122	91	72
SX, SN60-17	30	40		235	224	204	181	157	130	98	77
SX, SN60-18	30	40		251	240	219	194	166	140	105	84
SX, SN60-19	37	50		264	253	231	204	178	148	112	89
SX, SN60-20	37	50		277	265	242	214	186	155	118	94
SX, SN60-21	37	50		291	278	255	226	196	163	123	98

Size and weight

Model	Size (mm)				Weight (kg)
	A	B	C	ΦD	
SX, SN60-1	878	510	368	96	30
SX, SN60-2-2	1101	620	481	96	33
SX, SN60-2	1263	782	481	96/143	35/41
SX, SN60-3	1434	840	594	96/143	41/49
SX, SN60-4	1627	920	707	96/143	48/59
SX, SN60-5	1717	897	820	143	72
SX, SN60-6	1891	942	949	143	78
SX, SN60-7	2042	980	1062	143	87
SX, SN60-8-2	2155	980	1175	143	88
SX, SN60-8	2205	1030	1175	143	96
SX, SN60-9-2	2318	1030	1288	143	97
SX, SN60-9	2378	1090	1288	143	105
SX, SN60-10	2491	1090	1401	143	107
SX, SN60-11	2674	1160	1514	143	123
SX, SN60-12	2787	1160	1627	143	125
SX, SN60-13	2900	1160	1740	143	127
SX, SN60-14	3095	1242	1853	143	141
SX, SN60-15	3208	1242	1966	143	143
SX, SN60-16	3461	1382	2079	143	158
SX, SN60-17	3594	1382	2192	143	160
SX, SN60-18	3687	1382	2305	143	162
SX, SN60-19	3988	1570	2418	143	188
SX, SN60-20	4101	1570	2531	143	190
SX, SN60-21	4214	1570	2644	143	191

SX, SN 75

Performance curve ISO9906 Annex A 2850rpm

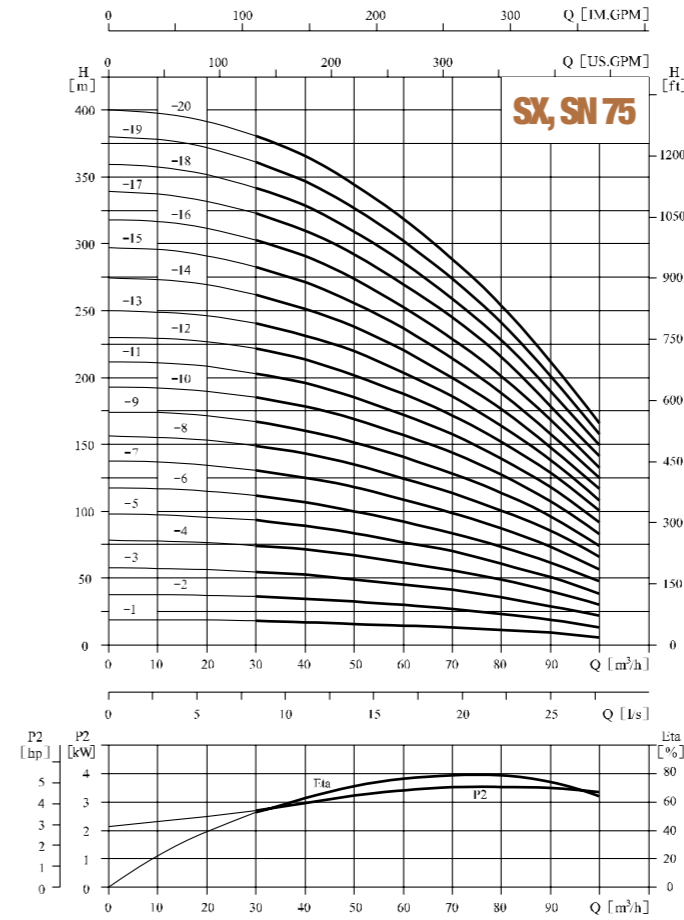

Installation sketch

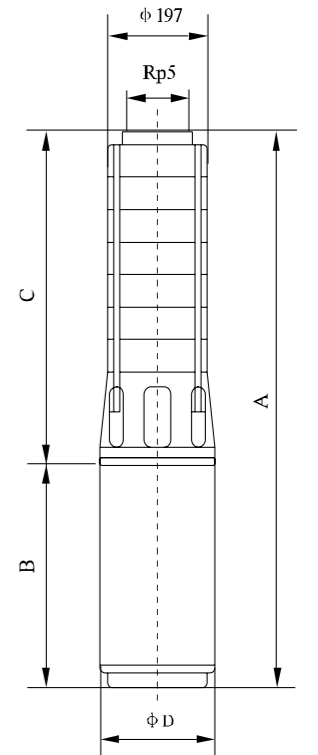

Performance table

Model	Driving motor		Q (m³/h)	H (m)															
	(kW)	(hp)		30	40	50	60	70	75	80	90	100							
SX, SN75-1	4	5.5		18	17	155	14.5	13	12	11	9	5.5							
SX, SN75-2	7.5	10		36.5	34.5	32	30	27	25	23	19	12.5							
SX, SN75-3	11	15		54.5	52.5	49	45	41	38	35.5	29	21.5							
SX, SN75-4	15	20		73.5	71	66.5	61	55.5	52	48	40	30							
SX, SN75-5	18.5	25		92	89	83	76	70	65	60.5	51	38							
SX, SN75-6	22	30		111	107	100	91	84	79	73	62	47							
SX, SN75-7	30	40		130	125	118	107	98	93	87	73	56							
SX, SN75-8	30	40		148	143	135	124	113	107	101	85	65							
SX, SN75-9	37	50		167	161	152	140	128	121	114	96	74							
SX, SN75-10	37	50		185	178	169	157	143	135	127	107	83							
SX, SN75-11	45	60		203	196	185	172	158	148	139	118	92							
SX, SN75-12	45	60		222	214	202	188	172	162	152	129	100							
SX, SN75-13	55	75		241	232	220	204	186	175	164	139	108							
SX, SN75-14	55	75		262	251	238	220	200	188	176	149	116							
SX, SN75-15	55	75		283	271	256	236	214	201	188	159	124							
SX, SN75-16	63	85		303	291	274	253	229	215	202	169	133							
SX, SN75-17	63	85		323	310	292	270	245	229	215	179	142							
SX, SN75-18	75	100		342	329	309	286	259	243	226	190	150							
SX, SN75-19	75	100		361	347	327	302	274	257	241	201	158							
SX, SN75-20	75	100		381	366	345	318	288	271	254	212	167							

Size and weight

Model	Size (mm)				Weight (kg)
	A	B	C	ΦD	
SX, SN75-1	1270	782	488	143	56
SX, SN75-2	1424/1411	810/780	614/631	143/184	78/97
SX, SN75-3	1660/1577	920/800	740/757	143/184	92/116
SX, SN75-4	1896/1743	1030/860	866/883	143/184	110/134
SX, SN75-5	2082/1899	1090/890	992/1009	143/184	122/152
SX, SN75-6	2278/2075	1160/940	1118/1135	143/184	141/178
SX, SN75-7	2574/2311	1330/1050	1244/1261	143/184	171/211
SX, SN75-8	2700/2437	1330/1050	1370/1387	143/184	176/216
SX, SN75-9	3066/2663	1570/1150	1496/1513	143/184	204/233
SX, SN75-10	3192/2789	1570/1150	1622/1639	143/184	209/238
SX, SN75-11	3005	1240	1765	184	256
SX, SN75-12	3131	1240	1891	184	261
SX, SN75-13	3387	1370	2017	184	279
SX, SN75-14	3513	1370	2143	184	285
SX, SN75-15	3639	1370	2269	184	290
SX, SN75-16	3885	1490	2395	192	309
SX, SN75-17	4011	1490	2521	192	315
SX, SN75-18	4187	1540	2647	192	341
SX, SN75-19	4313	1540	2773	192	346
SX, SN75-20	4439	1540	2899	192	351

SX, SN 95

Performance curve ISO9906 Annex A 2850rpm

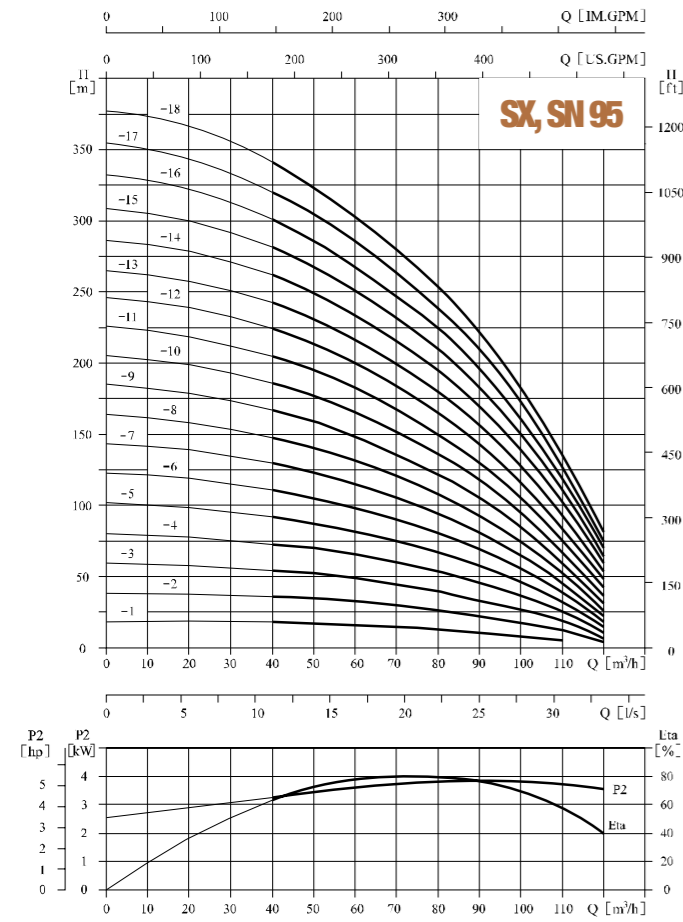

Installation sketch

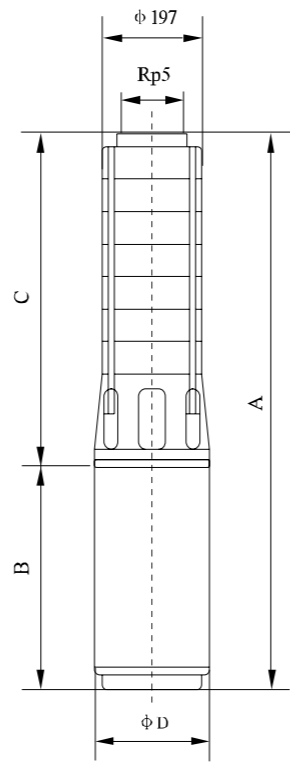

Performance table

Model	Driving motor		Q (m³/h)	H (m)												
	(kW)	(hp)		40	50	60	70	80	90	95	100	110	120			
SX, SN95-1	4	5.5	17.5	16.5	15.5	14	12.5	10.5	9.5	8	5	—				
SX, SN95-2	9.2	12.5	36	34	32	28.5	26	21.5	20	17	12	3.5				
SX, SN95-3	13	17.5	54	52	48.5	44.5	40	33	30	26	19	6				
SX, SN95-4	18.5	25	72	70	65	60	54	45	41	36	25.5	10.5				
SX, SN95-5	22	30	91	87	81.5	75	68	57	51.5	46	32	14.5				
SX, SN95-6	25	34	110	104	98	90	81	69	62	55	38	16				
SX, SN95-7	30	40	129	122	115	105	94	81	73	65	45	22				
SX, SN95-8	37	50	148	141	131	120	108	93	84	75	52	26				
SX, SN95-9	37	50	167	159	148	135	122	105	95	85	59	31				
SX, SN95-10	45	60	186	177	165	151	136	117	106	95	67	36				
SX, SN95-11	45	60	205	195	182	167	150	130	117	105	75	42				
SX, SN95-12	55	75	224	213	199	183	165	143	129	116	84	48				
SX, SN95-13	55	75	243	231	216	199	180	156	141	127	93	53				
SX, SN95-14	55	75	262	249	233	215	195	169	153	138	102	59				
SX, SN95-15	63	85	281	268	250	231	210	183	166	149	111	64				
SX, SN95-16	63	85	301	286	267	247	225	197	178	160	119	70				
SX, SN95-17	75	100	321	304	284	263	240	210	190	171	127	75				
SX, SN95-18	75	100	342	323	302	279	255	222	202	182	135	61				

Size and weight

Model	Size (mm)				Weight (kg)
	A	B	C	ΦD	
SX, SN95-1	1270	782	488	143	57
SX, SN95-2	1484/1431	870/800	614/631	143/184	83/105
SX, SN95-3	1720/1617	980/860	740/757	143/184	100/129
SX, SN95-4	1956/1773	1090/890	866/883	143/184	119/148
SX, SN95-5	2152/1949	1160/940	992/1009	143/184	138/175
SX, SN95-6	2348/2125	1230/990	1116/1135	143/184	155/188
SX, SN95-7	2574/2311	1330/1050	1244/1261	143/184	174/213
SX, SN95-8	2940/2537	1570/1150	1370/1387	143/184	202/231
SX, SN95-9	3066/2663	1570/1150	1496/1513	143/184	208/237
SX, SN95-10	2879	1240	1639	184	254
SX, SN95-11	3005	1240	1765	184	260
SX, SN95-12	3261	1370	1891	184	279
SX, SN95-13	3387	1370	2017	184	284
SX, SN95-14	3513	1370	2143	184	290
SX, SN95-15	3759	1490	2269	192	310
SX, SN95-16	3885	1490	2395	192	316
SX, SN95-17	4061	1540	2521	192	342
SX, SN95-18	4187	1540	2647	192	348

SX, SN 120

Performance curve ISO9906 Annex A 2850rpm

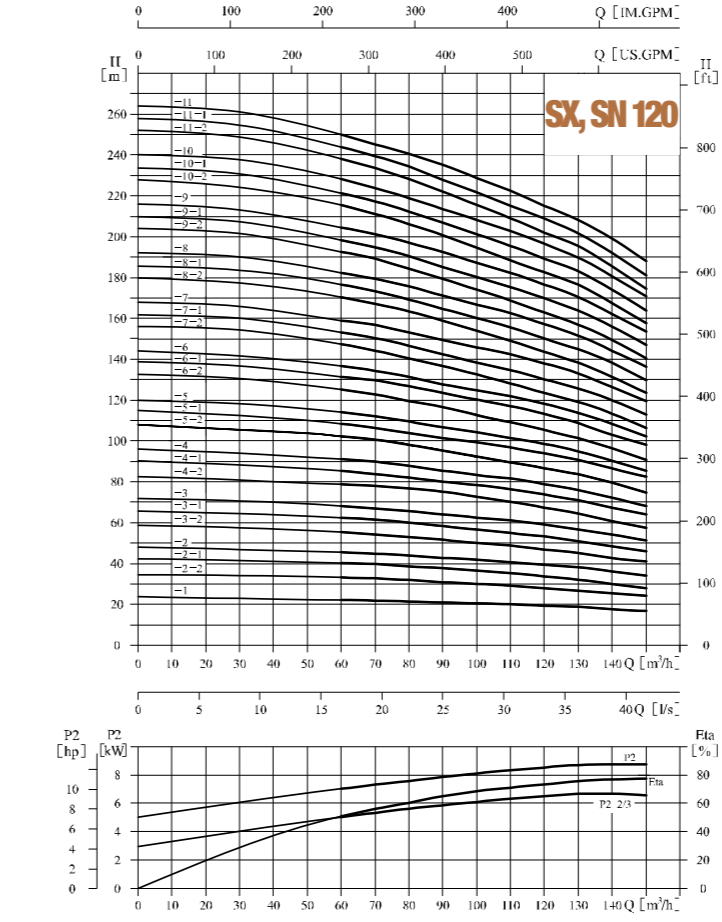

Installation sketch

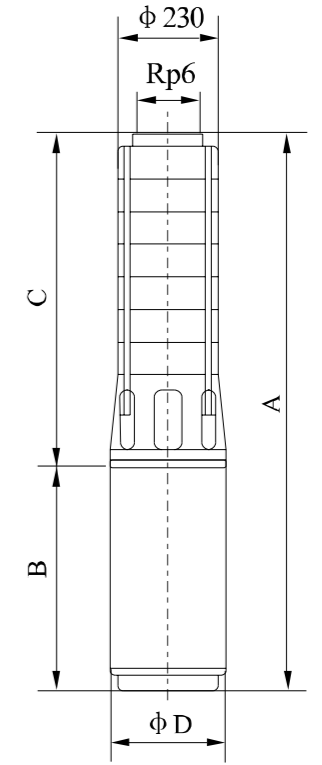

Performance table

Model	Driving motor		Q (m³/h)	H (m)														
	(kW)	(hp)		60	70	80	90	100	110	120	130	140	150					
SX, SN120-1	11	15	22.5	22	21.5	21	20.5	20	19	18.5	17.5	16.5						
SX, SN120-2-2	15	20	33.5	33	32	30	29	28.5	27.5	26.5	24.5	24						
SX, SN120-2-1	18.5	25	40.5	40	38.5	37.5	36	35.5	33.5	32.5	29.5	28						
SX, SN120-2	22	30	45.5	44.5	43.5	42.5	41.5	40.5	39	38	36	34						
SX, SN120-3-2	25	34	55	54.5	52.5	51	49.5	48.5	46.5	45	42.5	40.5						
SX, SN120-3-1	30	40	62.5	61.5	60	58	56	54	53.5	51	48.5	46						
SX, SN120-3	30	40	66	67	65.5	64	62	61	59	57	54	51						
SX, SN120-4-2	37	50	78.5	77	75	72.5	70.5	69	66.5	65	60.5	57.5						
SX, SN120-4-1	37	50	85	84	82	79.5	77	76	73.5	71	67	64						
SX, SN120-4	37	50	90.5	89.5	87.5	85.5	83	81.5	78.5	76	72	68						
SX, SN120-5-2	45	60	102	100.5	97.5	95	91.5	90	86.5	84	79	74.5						
SX, SN120-5-1	45	60	108.5	106.5	103.5	101	98.5	96.5	94	91	86.5	82						
SX, SN120-5	55	75	113.5	112	109.5	106.5	103.5	101.5	98.5	95	90	85						
SX, SN120-6-2	55	75	125	122.5	119	116.5	112.5	109	104.5	101.5	96	90.5						
SX, SN120-6-1	55	75	131	129.5	125.5	123.5	120	117	113	109	103	96						
SX, SN120-6	63	85	136	134.5	131	127.5	124.5	121.5	118	114	108	102						
SX, SN120-7-2	63	85	147	144	140.5	136.5	132.5	128	123	119	113	106						
SX, SN120-7-1	63	85	153	150	146.5	142.5	138.5	135	130	125.5	120	112.5						
SX, SN120-7	75	100	159	156.5	153	149	145	142	138	133	126	119.5						
SX, SN120-8-2	75	100	170	167	164.5	158	153	148.5	143	138	131.5	123						
SX, SN120-8-1	75	100	175.5	173	168.5	163.5	159	158.5	150	145	138	129.5						
SX, SN120-8	75	100	181.5	179.5	175	170.5	166	163	157.5	152.5	144	136.5						
SX, SN120-9-2	90	120	192.5	189	184	179.5	174	168.5	162.5	157	149.5	140						
SX, SN120-9-1	90	120	198	195	190.5	185	180	175.5	169.5	164	156	147						
SX, SN120-9	90	120	204	201.5	198	191.5	186.5	182.5	177.5	171.5	162	153.5						
SX, SN120-10-2	90	120	215.5	211	206	200.5	194.5	188.5	182.5	176.5	167.5	157.5						
SX, SN120-10-1	90	120	221	217	212	206.5	200.5	195.5	189.5	183	174	164						
SX, SN120-10	110	150	227	223.5	219	213	207.5	202.5	197	190.5	180	170.5						
SX, SN120-11-2	110	150	238	233	228	222	215.5	208	202	195.5	185.5	174.5						
SX, SN120-11-1	110	150	243.5	239.5	234	227.5	221.5	215	209	202	192	181						
SX, SN120-11	110	150	250	245.5	241	234.5	228	222.5	216.5	209.5	198.5	187.5						

Size and weight

Model	Size (mm)				Weight (kg)
	A	B	C	ΦD	
SX, SN120-1	1451/1380/-	920/820/-	531/560/-	144/184/-	96/121/-
SX, SN120-2-2	1721/1580/-	1030/860/-	691/720/-	144/184/-	111/135/-
SX, SN120-2-1	1781/1610/-	1090/890/-	691/720/-	144/184/-	118/140/-
SX, SN120-2	1921/1660/-	1230/940/-	691/720/-	144/184/-	127/155/-
SX, SN120-3-2	2093/1870/-	1242/990/-	851/880/-	144/184/-	142/173/-
SX, SN120-3-1	2233/1930/2002	1382/1050/1122	851/880/880	144/184/236	148/187/227
SX, SN120-3	2233/1930/2002	1362/1050/1122	851/880/880	144/184/236	148/187/227
SX, SN120-4-2	2581/2190/2202	1570/1150/1162	1011/1040/1040	144/184/236	166/210/252
SX, SN120-4-1	2581/2190/2202	1570/1150/1162	1011/1040/1040	144/184/236	166/210/252
SX, SN120-4	2581/2190/2202	1570/1150/1162	1011/1040/1040	144/184/236	166/210/252
SX, SN120-5-2	-/2440/2392	-/1240/1192	-/1200/1200	-/184/236	-/233/262
SX, SN120-5-1	-/2440/2392	-/1240/1192	-/1200/1200	-/184/236	-/233/282
SX, SN120-5	-/2570/2472	-/1370/1272	-/1200/1200	-/184/236	-/253/215
SX, SN120-6-2	-/2730/2632	-/1370/1272	-/1360/1360	-/184/236	-/314/323
SX, SN120-6-1	-/2730/2632	-/1370/1272	-/1360/1360	-/184/236	-/261/323
SX, SN120-6	-/2650/2692	-/1490/1332	-/1360/1360	-/192/236	-/288/341
SX, SN120-7-2	-/3010/2852	-/1490/1332	-/1520/1520	-/192/236	-/296/349
SX, SN120-7-1	-/3010/2852	-/1490/1332	-/1520/1520	-/192/236	-/296/349
SX, SN120-7	-/3060/2942	-/1540/1422	-/1520/1520	-/192/236	-/306/387
SX, SN120-8-2	-/3220/3102	-/1540/1422	-/1680/1680	-/192/236	-/314/395
SX, SN120-8-1	-/3220/3102	-/1540/1422	-/1680/1680	-/184/236	-/314/395
SX, SN120-8	-/3220/3102	-/1540/1422	-/1680/1680	-/192/236	-/314/395
SX, SN120-9-2	-/3484/3371	-/1644/1531	-/1840/1840	-/192/236	-/342/416
SX, SN120-9-1	-/3484/3371	-/1644/1531	-/1840/1840	-/192/236	-/342/416
SX, SN120-9	-/3484/3371	-/1644/1531	-/1840/1840	-/192/236	-/342/416
SX, SN120-10-2	-/3644/3531	-/1644/1531	-/2000/2000	-/192/236	-/350/424
SX, SN120-10-1	-/3544/3531	-/1644/1531	-/2000/2000	-/192/236	-/350/424
SX, SN120-10	-/3764/3641	-/1764/1641	-/2000/2000	-/192/236	-/376/461
SX, SN120-11-2	-/3924/3801	-/1764/1641	-/2160/2160	-/192/236	-/384/469
SX, SN120-11-1	-/3924/3801	-/1764/1641	-/2160/2160	-/192/236	-/384/469
SX, SN120-11	-/3924/3801	-/1764/1641	-/2160/2160	-/192/236	-/384/469

SX, SN 150

Performance curve ISO9906 Annex A 2850rpm

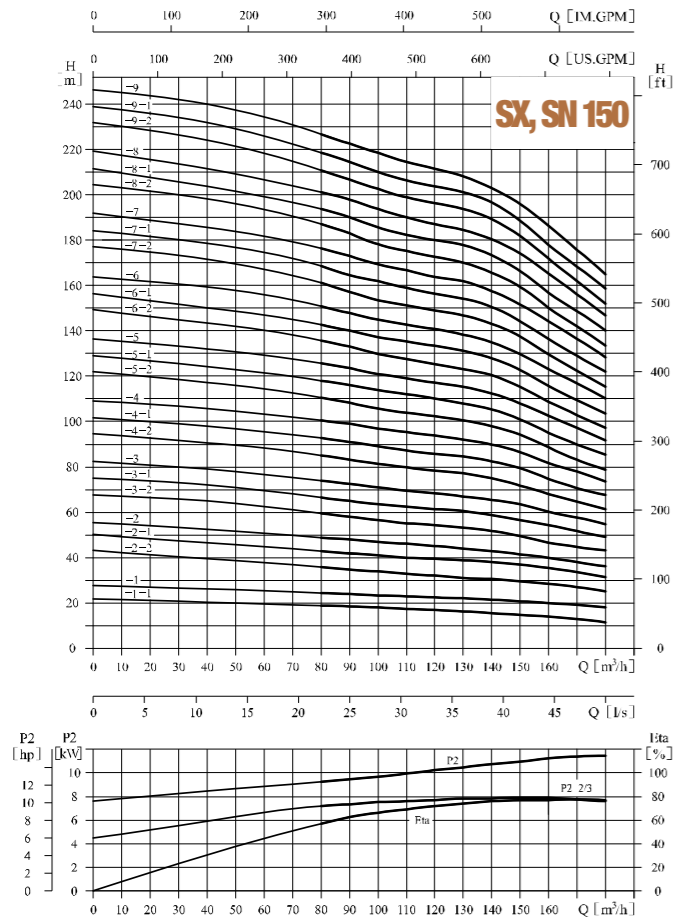

Installation sketch

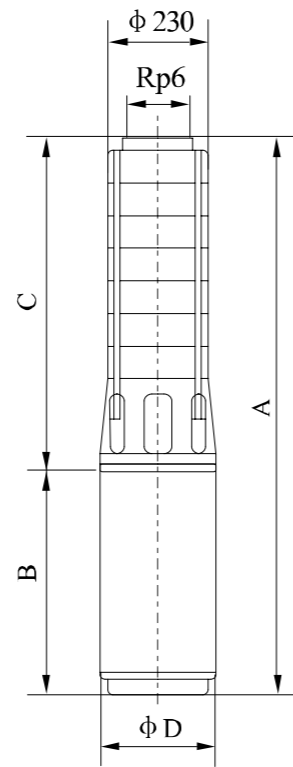

Performance table

Model	Driving motor		Q (m³/h)	H (m)															
	(kW)	(hp)		80	90	100	110	120	130	140	150	160	170	180					
SX, SN150-1-1	9.2	12.5		18.5	18	17.5	17	16.5	16	15	14.5	13.5	13	11.5					
SX, SN150-1	13	17.5		24	23.5	23	22.5	22	21.5	21	20	19.5	19	16					
SX, SN150-2-2	18.5	25		35.5	34	32	31.5	31	29.5	29	28.5	28	27	25					
SX, SN150-2-1	22	30		43	41.5	40	39	38.5	38	37.5	36	35.5	34	31					
SX, SN150-2	25	34		48.5	47.5	46	45	44.5	44	42.5	41	39.5	38	36					
SX, SN150-3-2	30	40		60	57	54.5	54	53.5	53	52.5	49.5	46.5	44.5	43					
SX, SN150-3-1	37	50		66.5	64	62.5	61.5	60.5	60	59.5	56.5	54	51.5	49					
SX, SN150-3	37	50		74.5	72.5	70.5	69.5	66	67.5	65.5	63.5	60	57.5	54.5					
SX, SN150-4-2	45	60		85.5	83	80	79	77.5	77	76	73	66.5	63.5	61					
SX, SN150-4-1	45	60		93	90	87.5	86.5	84.5	83.5	83	79.5	73.5	70.5	67					
SX, SN150-4	55	75		100.5	98	94.5	94	92.5	89.5	86.5	80.5	77.5	73						
SX, SN150-5-2	55	75		111.5	107	104	103	102	101	98	94	66.5	61.5	78.5					
SX, SN150-5-1	55	75		118.5	114.5	112	110.5	108.5	107	105.5	101	94	89.5	85					
SX, SN150-5	63	85		126	122.5	120	118	116	115	112.5	108.5	101.5	97	91.5					
SX, SN150-6-2	63	85		137	131.5	128	126.5	123	122	120.5	115.5	107	101	97					
SX, SN150-6-1	75	100		144	139	136	134	132	131.5	128	122.5	114.5	109	103.5					
SX, SN150-6	75	100		151.5	147	144	141.5	139.5	136	135	130	122	116.5	110					
SX, SN150-7-2	75	100		162.5	156	152.5	150.5	146	145	143	138	126	121	115					
SX, SN150-7-1	90	120		169.5	163.5	160.5	158	155	153	150.5	145	135.5	129	121.5					
SX, SN150-7	90	120		177	171.5	168.5	165.5	163.5	162.5	157.5	152.5	143	136.5	128					
SX, SN150-8-2	90	120		188	180.5	177	174.5	172	171	165.5	160.5	149	140.5	133.5					
SX, SN150-8-1	110	150		195	188	185	182	180	178.5	173	168.5	156.5	148.5	140					
SX, SN150-8	110	150		202.5	196	193	189.5	187	186	180	175	164	156	146.5					
SX, SN150-9-2	110	150		213.5	205	201.5	198	196	194	188.5	182.5	170.5	160	152					
SX, SN150-9-1	110	150		220.5	212.5	209.5	205.5	203	201.5	196	189.5	178	166	158.5					
SX, SN150-9	110	150		228	220.5	217.5	213	210	209	203	197	185.5	175.5	165					

Size and weight

Model	Size (mm)				Weight (kg)
	A	B	C	ΦD	
SX, SN150-1-1	1428/1360/-	897/800/-	531/560/-	144/148/-	92/117/-
SX, SN150-1	1561/1420/-	1030/860/-	531/560/-	144/148/-	100/124/-
SX, SN150-2-2	1781/1610/-	1090/890/-	691/720/-	144/148/-	119/141/-
SX, SN150-2-1	1851/1660/-	1160/940/-	691/720/-	144/148/-	128/156/-
SX, SN150-2	1933/1710/-	1242/990/-	691/720/-	144/148/236	135/166/-
SX, SN150-3-2	2233/1930/2002	1382/1050/1222	851/380/880	144/184/236	149/188/228
SX, SN150-3-1	2421/2030/2042	1570/1150/1162	851/880/880	144/184/236	158/202/246
SX, SN150-3	2421/2030/2042	1570/1150/1162	851/380/880	144/134/236	158/202/246
SX, SN150-4-2	-/2280/2232	-/1240/1192	-/1040/1040	-/184/236	-/225/274
SX, SN150-4-1	-/2280/2232	-/1240/1192	-/1040/1040	-/184/236	-/225/274
SX, SN150-4	-/2410/2312	-/1370/1272	-/1040/1040	-/184/236	-/245/307
SX, SN150-5-2	-/2570/2472	-/1370/1272	-/1200/1200	-/184/236	-/253/315
SX, SN150-5-1	-/2571/2472	-/1370/1272	-/1200/1200	-/184/236	-/253/315
SX, SN150-5	-/2690/2532	-/1490/1332	-/1200/1200	-/192/236	-/280/333
SX, SN150-6-2	-/2850/2692	-/1490/1332	-/1360/1360	-/192/236	-/288/341
SX, SN150-6-1	-/2900/2782	-/1540/1422	-/1360/1360	-/192/236	-/298/379
SX, SN150-6	-/2900/2782	-/1540/1422	-/1360/1360	-/192/236	-/298/379
SX, SN150-7-2	-/3060/2942	-/1540/1422	-/1520/1520	-/192/236	-/306/387
SX, SN150-7-1	-/3164/3051	-/1644/1531	-/1520/1520	-/192/236	-/326/400
SX, SN150-7	-/3164/3051	-/1644/1531	-/1520/1520	-/192/236	-/326/400
SX, SN150-8-2	-/3324/3211	-/1644/1531	-/1680/1680	-/192/236	-/334/408
SX, SN150-8-1	-/3444/3321	-/1764/1641	-/1680/1680	-/192/236	-/360/426
SX, SN150-8	-/3444/3321	-/1764/1641	-/1680/1680	-/192/236	-/360/426
SX, SN150-9-2	-/3604/3481	-/1764/1641	-/1840/1840	-/192/236	-/369/435
SX, SN150-9-1	-/3604/3481	-/1764/1641	-/1840/1840	-/192/236	-/369/435
SX, SN150-9	-/3604/3481	-/1764/1641	-/1840/1840	-/192/236	-/369/435

SX, SN 200

Performance curve ISO9906 Annex A 2850rpm

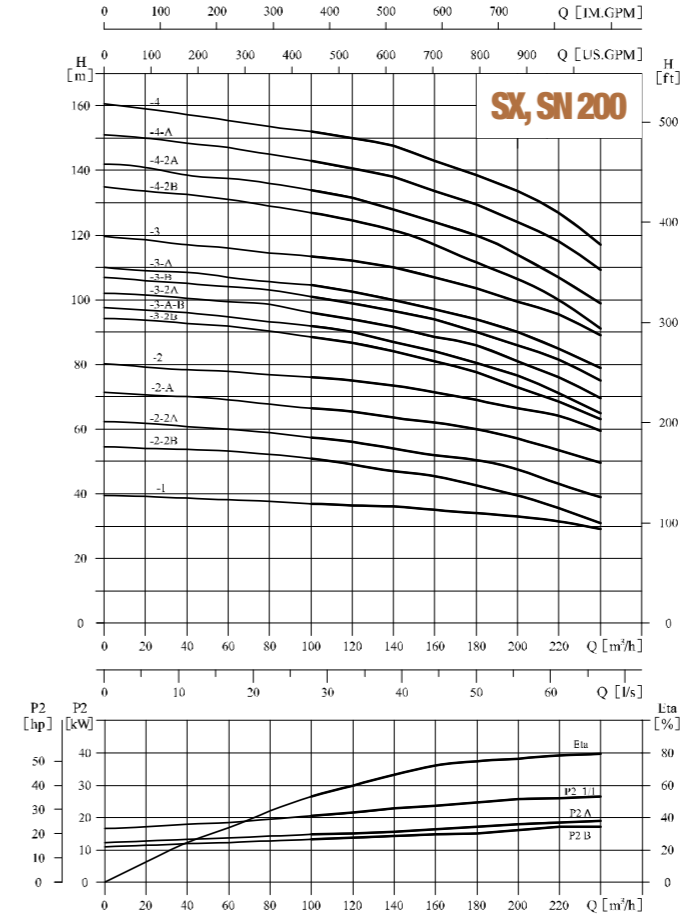

Installation sketch

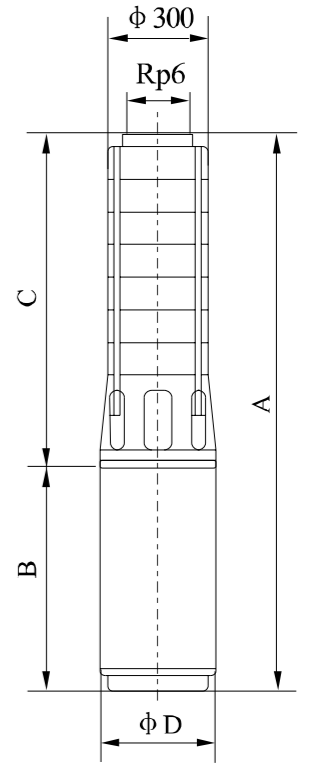

Performance table

Model	Driving motor		Q (m³/h)	H (m)							
	(kW)	(hp)		100	120	140	160	180	200	220	240
SX, SN200-1	30	40		37	36.5	36	35	34	33	31.5	29
SX, SN200-2-2B	37	50		51	49	47	45.5	42.5	39.5	35.5	31
SX, SN200-2-2A	45	60		57.5	56	54	52	50.5	47.5	43	39
SX, SN200-2-A	55	75		66.5	65.5	63.5	62	60	57	53.5	49.5
SX, SN200-2	55	75		76	75	73.5	71.5	69	66.5	64	59.5
SX, SN200-3-2B	75	100		68.5	67	64	61	58	54.5	50.5	46.5
SX, SN200-3-A-B	75	100		92	90	87	84	80.5	76.5	71	65
SX, SN200-3-2A	75	100		96	94	91.5	88.5	86	81	76	69.5
SX, SN200-3-B	75	100		101	99	96.5	94	90	86	81.5	109.5
SX, SN200-3-A	75	100		104.5	102.5	100	97	94	90	85	75
SX, SN200-3	90	120		113.5	112	110	107	103.5	99.5	95.5	79
SX, SN200-4-2B	90	120		127	124.5	121.5	117	111.5	106.5	100	89
SX, SN200-4-2A	110	150		134	131.5	127.5	124	120	114	107	91
SX, SN200-4-A	110	150		143	140.5	138	133.5	129.5	124	118	99
SX, SN200-4	110	150		152	150	147.5	143	136.5	133.5	127	117

Size and weight

Model	Size (mm)				Weight (kg)
	A	B	C	ΦD	
SX, SN17-1	708	380	328	96	17
SX, SN17-2	828	440	388	96	21
SX, SN17-3	959	510	449	96	28
SX, SN17-4	1019	510	509	96	29
SX, SN17-S	1190	620	570	96	32
SX, SN17-6	1412	782	630	96/143	35/41
SX, SN17-7	1441	782	691	96/143	36/42
SX, SN17-8	1591	S40	751	96/143	41/49
SX, SN17-9	1652	840	812	96/143	42/50
SX, SN17-10	1712	840	872	96/143	43/51
SX, SN17-11	1853	920	933	96/143	49/60
SX, SN17-12	1913	920	993	96/143	50/61
SX, SN17-13	1974	920	1054	96/143	51/62
SX, SN17-14	2027	897	1130	143	75
SX, SN17-15	2088	897	1191	143	76

SX, SN, SD 6 65

Performance curve ISO9906 Annex A 2850rpm

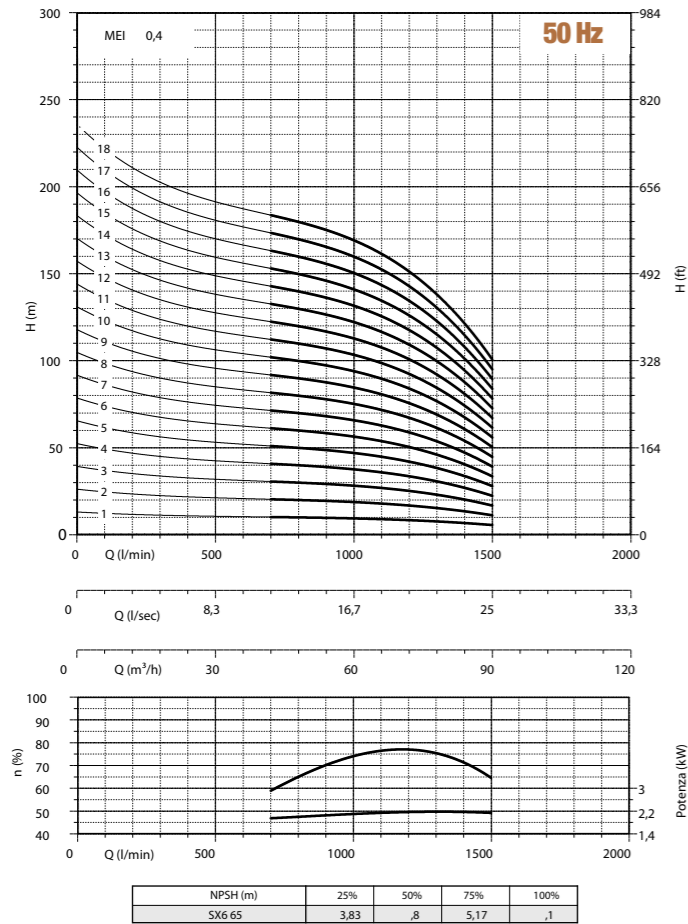

Installation sketch

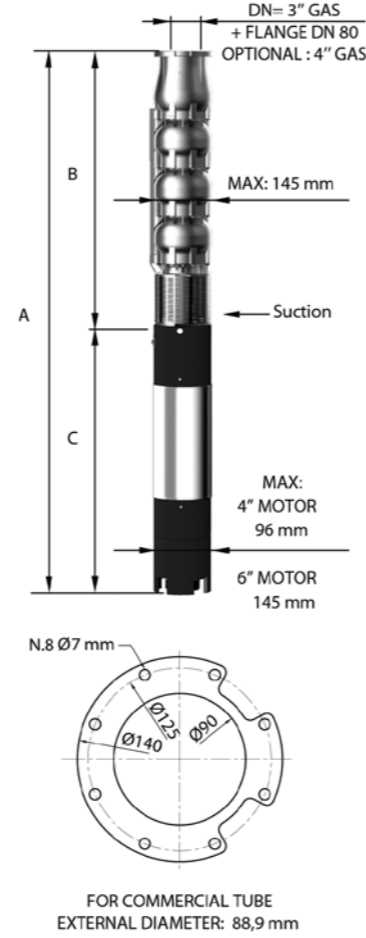

SX SN SD 8 80

Performance curve ISO9906 Annex A 2850rpm

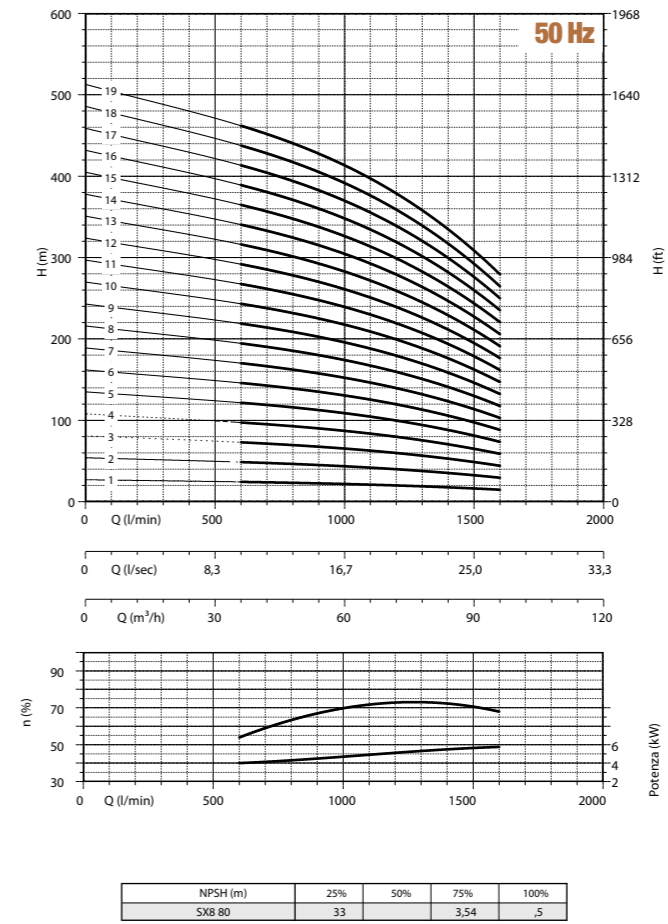

Installation sketch

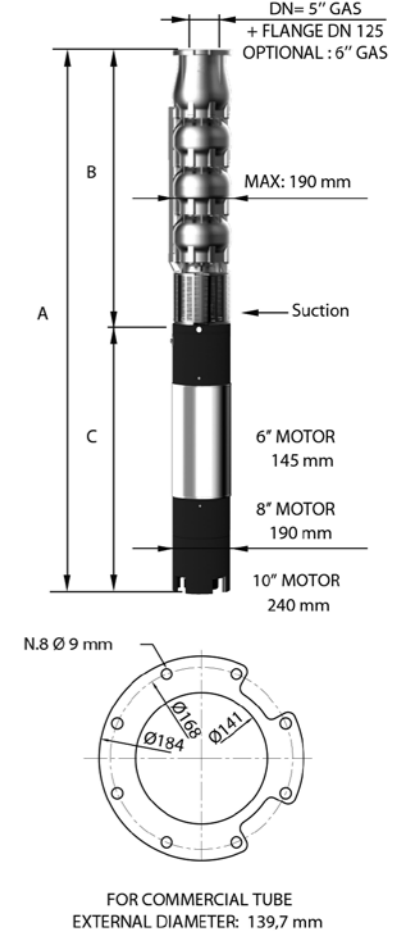

Performance table

Model	Driving motor		l/m	0	700	800	900	1000	1100	1200	1300	1400	1500
	(kW)	(hp)											
m³/h	0	42	48	54	60	66	72	78	84	90			
SX, SN, SD6 65-01	2,20	3	H	13	10	9,9	9,6	9,3	9	8,6	8	7	6
SX, SN, SD6 65-02	4	5,5	H	26	21	20	19,5	19	18	17	15	13	11
SX, SN, SD6 65-03	7,50	10	H	39	31	30	29	28	27	26	23	20	17
SX, SN, SD6 65-04	9,20	12,5	H	52	41	40	38	37	36	34	31	27	23
SX, SN, SD6 65-05	11	15	H	66	52	50	48	47	45	43	38	33	28
SX, SN, SD6 65-06	13	17,5	H	79	62	59	57	56	55	51	46	40	34
SX, SN, SD6 65-07	15	20	H	92	73	69	67	66	64	60	53	46	39
SX, SN, SD6 65-08	18,50	25	H	105	83	79	76	75	73	68	61	53	45
SX, SN, SD6 65-09	22	30	H	118	93	89	86	84	82	77	69	60	51
SX, SN, SD6 65-10	22	30	H	131	104	99	95	94	91	85	76	66	56
SX, SN, SD6 65-11	26	35	H	144	114	109	105	103	100	94	84	73	62
SX, SN, SD6 65-12	26	35	H	157	124	119	114	112	109	102	92	80	68
SX, SN, SD6 65-13	30	40	H	170	135	129	124	122	118	111	99	86	73
SX, SN, SD6 65-14	30	40	H	183	145	139	134	131	127	120	107	93	79
SX, SN, SD6 65-15	37	50	H	197	155	149	143	140	136	128	114	99	84
SX, SN, SD6 65-16	37	50	H	210	166	158	153	150	145	137	122	106	90
SX, SN, SD6 65-17	37	50	H	223	176	168	162	159	155	145	130	113	96
SX, SN, SD6 65-18	37	50	H	236	186	178	172	168	164	154	137	119	101

Size and weight

Model	Size (mm)				Weight (kg)
	A	B	C	M	
SX,SN,SD6 65-01	853	400	452	15	12
SX,SN,SD6 65-02	1104	507	597	22	15
SX,SN,SD6 65-03	1432	614	818	32	19
SX,SN,SD6 65-04	1472	721	751	60	23
SX,SN,SD6 65-05	1639	828	811	65	27
SX,SN,SD6 65-06	1776	935	841	70	32
SX,SN,SD6 65-07	1973	1042	931	75	36
SX,SN,SD6 65-08	2140	1149	991	83	40
SX,SN,SD6 65-09	2327	1256	1071	92	44
SX,SN,SD6 65-10	2434	1363	1071	92	48
SX,SN,SD6 65-11	2651	1470	1181	100	53
SX,SN,SD6 65-12	2758	1577	1181	100	57
SX,SN,SD6 65-13	2935	1684	1251	108	61
SX,SN,SD6 65-14	3042	1791	1251	108	65
SX,SN,SD6 65-15	3239	1898	1341	118	70
SX,SN,SD6 65-16	3346	2005	1341	118	75
SX,SN,SD6 65-17	3453	2112	1341	118	80
SX,SN,SD6 65-18	3560	2219	1341	118	85

Performance table

Model	Driving motor		l/m	0	600	800	1000	1200	1400	1600
	(kW)	(hp)								
m³/h	0	36	48	60	72	84	96			
SX, SN, SD8 80-01	7,50	10	H	27	24	23	22	20	18	15
SX, SN, SD8 80-02	11	15	H	54	49	47	44	40	35	30
SX, SN, SD8 80-03	18,50	25	H	81	73	70	65	60	53	44
SX, SN, SD8 80-04	26	35	H	108	97	93	87	80	70	59
SX, SN, SD8 80-05	30	40	H	135	121	116	109	100	88	74
SX, SN, SD8 80-06	37	50	H	162	146	140	131	120	105	89
SX, SN, SD8 80-07	44	60	H	189	170	163	152	140	123	103
SX, SN, SD8 80-08	55	75	H	216	194	186	174	160	140	118
SX, SN, SD8 80-09	55	75	H	243	218	209	196	180	158	133
SX, SN, SD8 80-10	66	90	H	270	243	233	218	200	175	148
SX, SN, SD8 80-11	66	90	H	297	267	256	239	220	193	162
SX, SN, SD8 80-12	75	100	H	324	291	279	261	240	210	177
SX, SN, SD8 80-13	75	100	H	351	315	302	283	260	228	192
SX, SN, SD8 80-14	92	125	H	378	340	326	305	280	245	207
SX, SN, SD8 80-15	92	125	H	405	364	349	326	300	263	221
SX, SN, SD8 80-16	92	125	H	432	388	372	348	320	280	236
SX, SN, SD8 80-17	110	150	H	459	412	395	370	340	298	251
SX, SN, SD8 80-18	110	150	H	486	437	419	392	360	315	266
SX, SN, SD8 80-19	110	150	H	513	461	442	413	380	333	280

Size and weight

Model	Size (mm)				Weight (kg)
	A	B	C	M	
SX,SN,SD8 80-01	1226	525	701	55	19
SX,SN,SD8 80-02	1461	650	811	65	26
SX,SN,SD8 80-03	1766	775	991	83	32
SX,SN,SD8 80-04	2081	900	1181	100	39
SX,SN,SD8 80-05	2276	1025	1251	108	45
SX,SN,SD8 80-06	2491	1150	1341	118	52
SX,SN,SD8 80-07	2398	1275	1123	178	58
SX,SN,SD8 80-08	2633	1400	1233	200	65
SX,SN,SD8 80-09	2758	1525	1233	200	71
SX,SN,SD8 80-10	2953	1650	1303	214	78
SX,SN,SD8 80-11	3078	1775	1303	214	84
SX,SN,SD8 80-12	3283	1900	1383	230	91
SX,SN,SD8 80-13	3408	2025	1383	230	97
SX,SN,SD8 80-14	3733	2150	1583	270	104
SX,SN,SD8 80-15	3858	2275	1583	270	110
SX,SN,SD8 80-16	3983	2400	1583	270	117
SX,SN,SD8 80-17	4258	2525	1733	300	123
SX,SN,SD8 80-18	4383	2650	1733	300	130
SX,SN,SD8 80-19	4508	2775	1733	300	136

SX, SN, SD 8 90

Performance curve ISO9906 Annex A 2850rpm

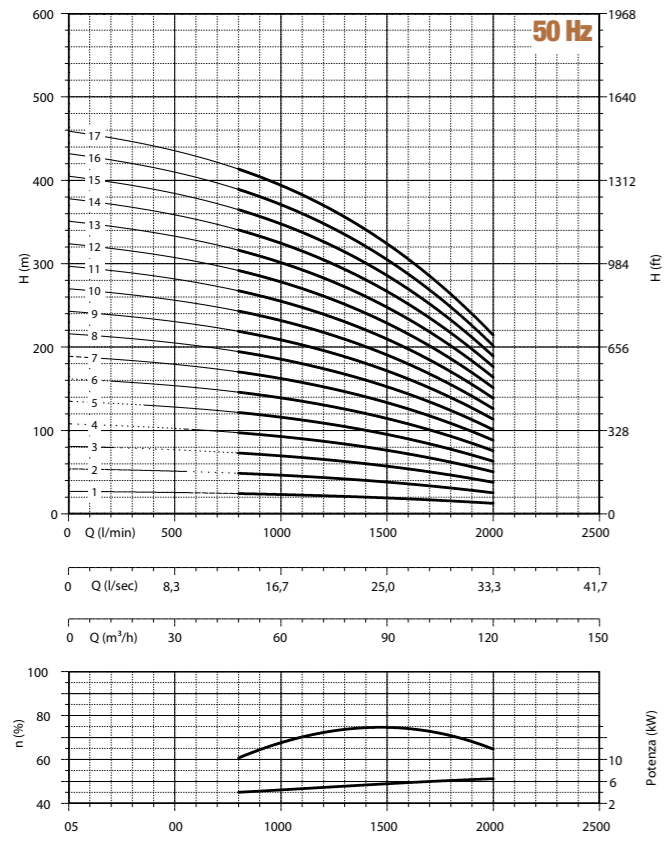

NPSH (m)	25%	50%	75%	100%
SX8 90	2,52	,9	3,97	,8

Installation sketch

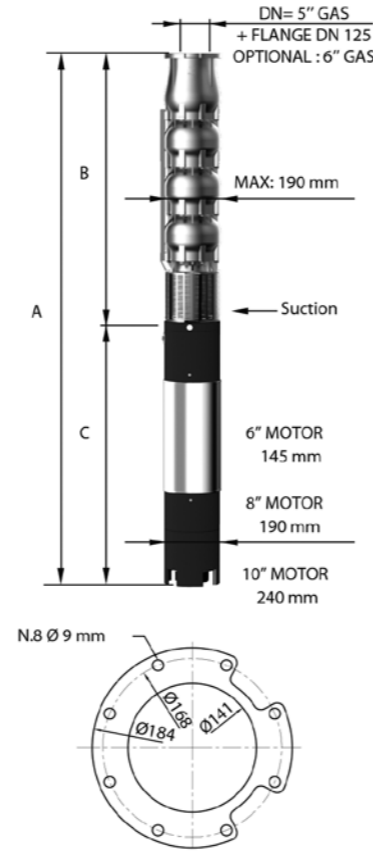

FOR COMMERCIAL TUBE
EXTERNAL DIAMETER: 139,7 mm

SX SN SD 8 100

Performance curve ISO9906 Annex A 2850rpm

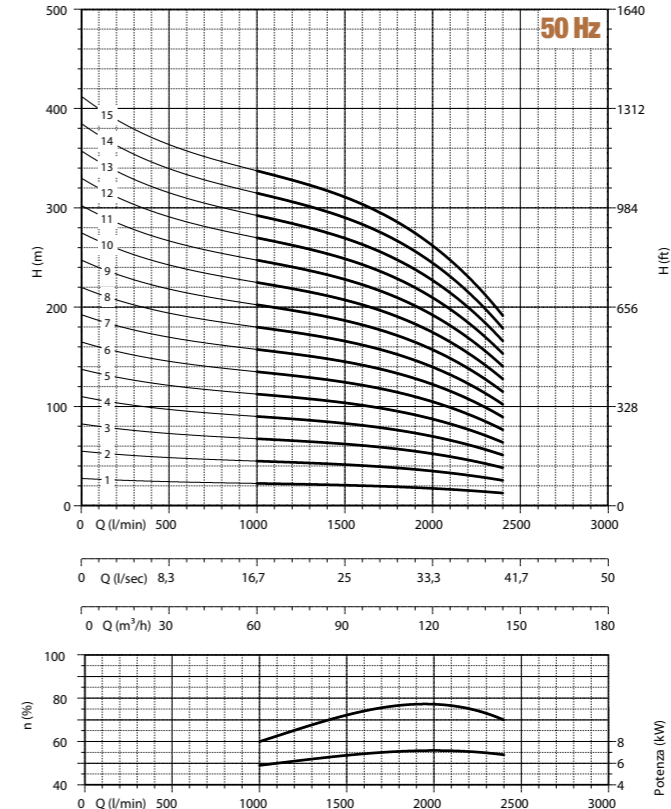

NPSH (m)	25%	50%	75%	100%
SX8 100	2,52	,9	3,97	,8

Installation sketch

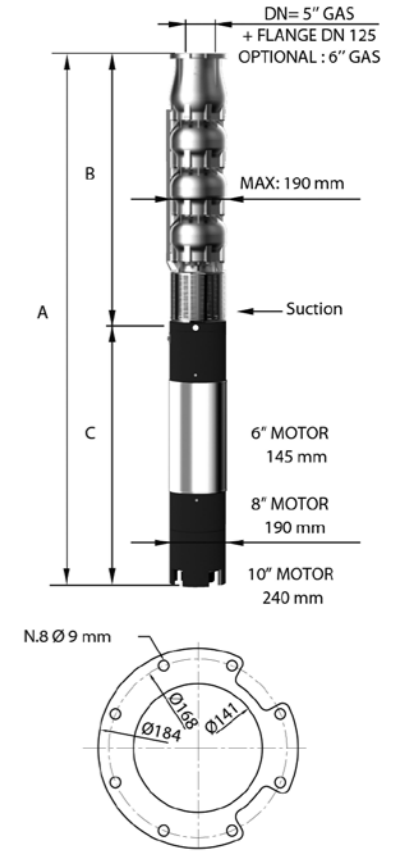

FOR COMMERCIAL TUBE
EXTERNAL DIAMETER: 139,7 mm

Performance table

Model	Driving motor		l/m	Flow rate (Q)									
	(kW)	(hp)		0	800	1000	1200	1400	1600	1800	2000		
				l/sec	13,33	16,67	20	23,33	26,67	30	33,33		
				m³/h	48	60	72	84	96	108	120		
SX, SN, SD8 90-01	7,50	10	27	24	23	22	20	18	16	13			
SX, SN, SD8 90-02	13	17,5	54	49	47	44	40	36	31	25			
SX, SN, SD8 90-03	22	30	81	73	70	65	60	54	47	38			
SX, SN, SD8 90-04	26	35	108	97	93	87	80	71	62	50			
SX, SN, SD8 90-05	37	50	135	121	116	109	101	89	78	63			
SX, SN, SD8 90-06	44	60	162	146	140	131	121	107	93	76			
SX, SN, SD8 90-07	44	60	189	170	163	152	141	125	109	88			
SX, SN, SD8 90-08	55	75	216	194	186	174	161	143	124	101			
SX, SN, SD8 90-09	66	90	243	218	209	196	181	161	140	114			
SX, SN, SD8 90-10	66	90	270	243	233	218	201	179	155	126			
SX, SN, SD8 90-11	75	100	297	267	256	239	221	197	171	139			
SX, SN, SD8 90-12	92	125	324	291	279	261	241	214	186	151			
SX, SN, SD8 90-13	92	125	351	315	302	283	262	232	202	164			
SX, SN, SD8 90-14	92	125	378	340	326	305	282	250	217	177			
SX, SN, SD8 90-15	110	150	405	364	349	326	302	268	233	189			
SX, SN, SD8 90-16	110	150	432	388	372	348	322	286	248	202			
SX, SN, SD8 90-17	110	150	459	412	395	370	342	304	264	215			

Size and weight

Model	Size (mm)				Weight (kg)
	A	B	C	M	
SX,SN,SD8 90-01	1226	525	701	55	19
SX,SN,SD8 90-02	1491	650	841	70	26
SX,SN,SD8 90-03	1846	775	1071	92	32
SX,SN,SD8 90-04	2081	900	1181	100	39
SX,SN,SD8 90-05	2366	1025	1341	118	45
SX,SN,SD8 90-06	2273	1150	1123	178	52
SX,SN,SD8 90-07	2398	1275	1123	178	58
SX,SN,SD8 90-08	2633	1400	1233	200	65
SX,SN,SD8 90-09	2828	1525	1303	214	71
SX,SN,SD8 90-10	2953	1650	1303	214	78
SX,SN,SD8 90-11	3158	1775	1383	230	84
SX,SN,SD8 90-12	3483	1900	1583	270	91
SX,SN,SD8 90-13	3608	2025	1583	270	97
SX,SN,SD8 90-14	3733	2150	1583	270	104
SX,SN,SD8 90-15	4008	2275	1733	300	110
SX,SN,SD8 90-16	4133	2400	1733	300	117
SX,SN,SD8 90-17	4258	2525	1733	300	123

Performance table

Model	Driving motor		l/m	Flow rate (Q)									
	(kW)	(hp)		0	1000	1200	1400	1600	1800	2000	2200	2400	
				l/sec	16,67	20	23,33	26,67	30	33,33	36,67	40	
				m³/h	60	72	84	96	108	120	132	144	
SX, SN, SD8 100-01	7,50	10	28	23	22	21	20	19	17	15	13		
SX, SN, SD8 100-02	15	20	55	45	44	42	41	38	35	31	26		
SX, SN, SD8 100-03	22	30	83	68	65	63	61	57	52	46	38		
SX, SN, SD8 100-04	30	40	110	90	87	84	82	76	69	62	51		
SX, SN, SD8 100-05	37	50	138	113	109	106	102	96	87	77	64		
SX, SN, SD8 100-06	44	60	165	135	131	127	122	115	104	92	77		
SX, SN, SD8 100-07	55	75	193	158	153	148	143	134	121	108	90		
SX, SN, SD8 100-08	66	90	220	180	174	169	163	153	138	123	102		
SX, SN, SD8 100-09	66	90	248	203	196	190	184	172	156	139	115		
SX, SN, SD8 100-10	75	100	275	225	218	211	204	191	173	154	128		
SX, SN, SD8 100-11	92	125	303	248	240	232	224	210	190	169	141		
SX, SN, SD8 100-12	92	125	330	270	262	253	245	229	208	185	154		
SX, SN, SD8 100-13	110	150	358	293	283	274	265	248	225	200	166		
SX, SN, SD8 100-14	110	150	385	315	305	295	286	267	242	216	179		
SX, SN, SD8 100-15	110	150	413	338	327	317	306	287	260	231	192		

Size and weight

Model	Size (mm)				Weight (kg)
	A	B	C	M	
SX,SN,SD8 100-01	1226	525	701	55	19
SX,SN,SD8 100-02	1581	650	931	75	26
SX,SN,SD8 100-03	1846	775	1071	92	33
SX,SN,SD8 100-04	2151	900	1251	108	40
SX,SN,SD8 100-05	2366	1025	1341	118	47
SX,SN,SD8 100-06	2273	1150	1123	178	53
SX,SN,SD8 100-07	2508	1275	1233	200	60
SX,SN,SD8 100-08	2703	1400	1303	214	67
SX,SN,SD8 100-09	2828	1525	1303	214	74
SX,SN,SD8 100-10	3033	1650	1383	230	81
SX,SN,SD8 100-11	3358	1775	1583	270	87
SX,SN,SD8 100-12	3483	1900	1583	270	94
SX,SN,SD8 100-13	3758	2025	1733	300	101
SX,SN,SD8 100-14	3883	2150	1733	300	108
SX,SN,SD8 100-15	4008	2275	1733	300	115

SX, SN, SD 8 125

Performance curve ISO9906 Annex A 2850rpm

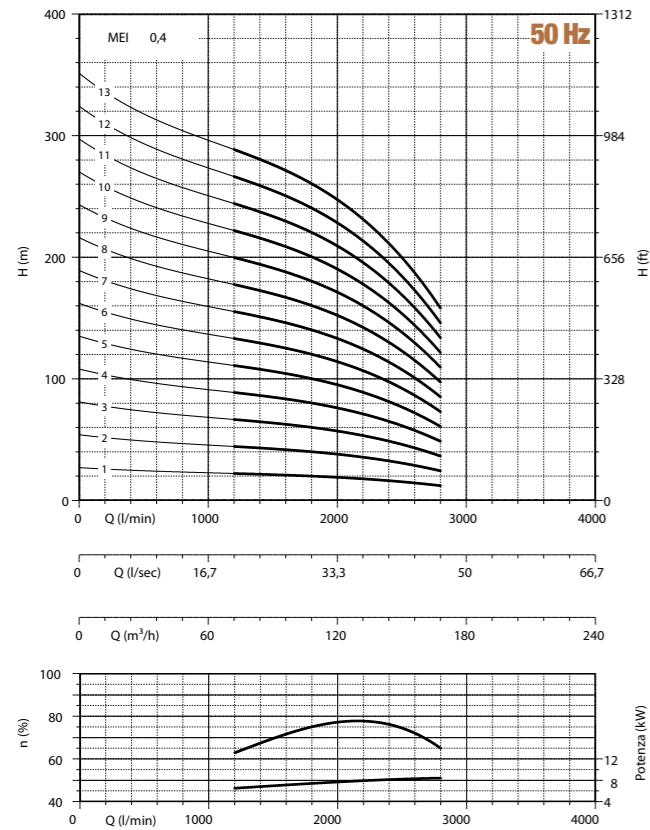

NPSH (m)	25%	50%	75%	100%
SX8 125	2,53		3,58	,7

Installation sketch

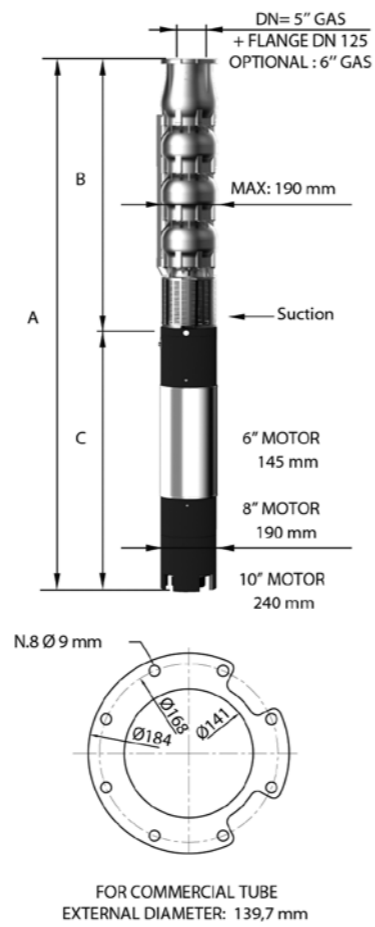

SX SN SD 8 145

Performance curve ISO9906 Annex A 2850rpm

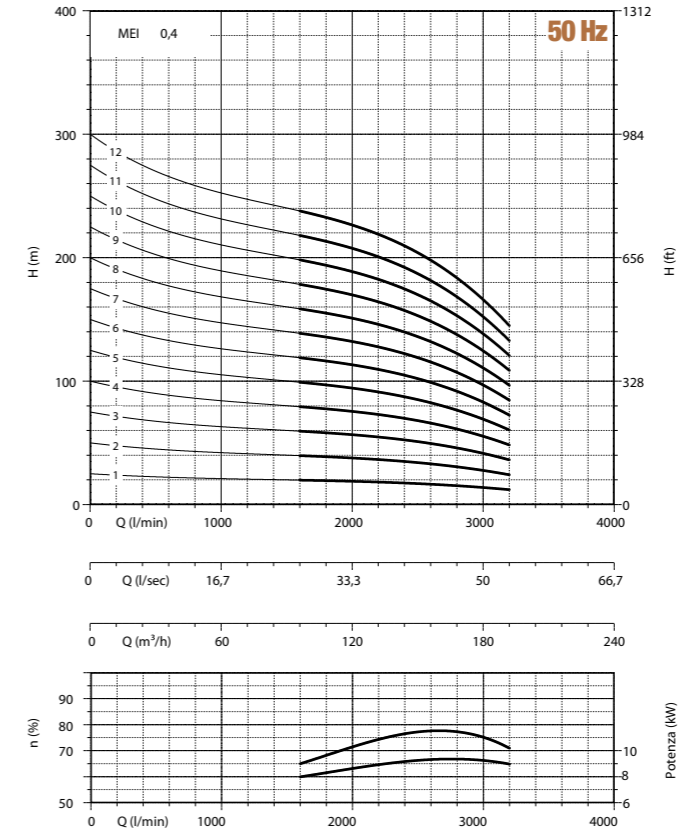

NPSH (m)	25%	50%	75%	100%
SX8 150	44	,5	71	3

Installation sketch

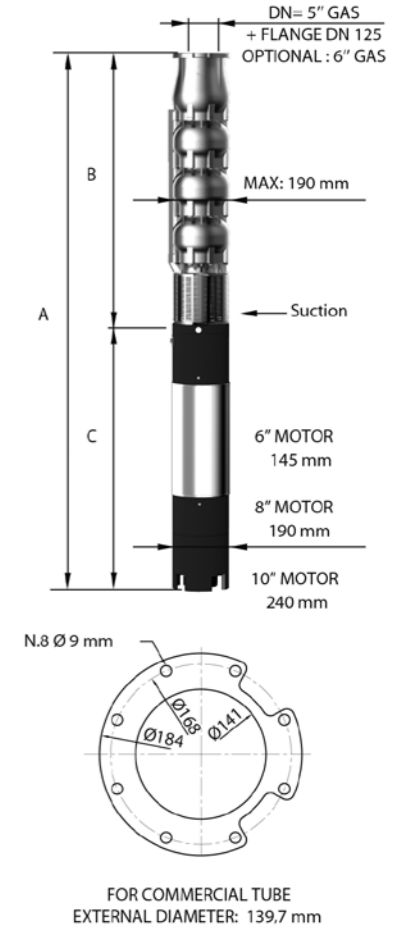

Performance table

Model	Driving motor		l/m	Flow rate (Q)											
	(kW)	(hp)		0	1200	1400	1600	1800	2000	2200	2400	2600	2800		
				l/sec	0	20	23,33	26,67	30	33,33	36,67	40	43,33	46,67	
SX, SN, SD8 125-01	9,20	12,5	27	23	22	21	20	19	18	16	15	12			
SX, SN, SD8 125-02	18,50	25	54	45	43	41	40	38	36	33	29	24			
SX, SN, SD8 125-03	26	35	81	68	65	62	59	57	54	49	44	36			
SX, SN, SD8 125-04	37	50	108	90	86	83	79	76	72	66	58	48			
SX, SN, SD8 125-05	44	60	135	113	108	104	99	95	90	82	73	60			
SX, SN, SD8 125-06	55	75	162	135	129	124	119	114	108	98	87	72			
SX, SN, SD8 125-07	66	90	189	158	151	145	139	133	126	115	102	84			
SX, SN, SD8 125-08	66	90	216	180	172	166	158	152	144	131	116	96			
SX, SN, SD8 125-09	75	100	243	203	194	186	178	171	162	148	131	108			
SX, SN, SD8 125-10	92	125	270	225	215	207	198	190	180	164	145	120			
SX, SN, SD8 125-11	92	125	297	248	237	228	218	209	198	180	160	132			
SX, SN, SD8 125-12	110	150	324	270	258	248	238	228	216	197	174	144			
SX, SN, SD8 125-13	110	150	351	293	280	269	257	247	234	213	189	156			

Size and weight

Model	Size (mm)				Weight (kg)
	A	B	C	M	
SX, SN, SD8 125-01	1276	525	751	60	20
SX, SN, SD8 125-02	1641	650	991	83	27
SX, SN, SD8 125-03	1956	775	1181	100	34
SX, SN, SD8 125-04	2241	900	1341	118	41
SX, SN, SD8 125-05	2148	1025	1123	178	48
SX, SN, SD8 125-06	2383	1150	1233	200	55
SX, SN, SD8 125-07	2578	1275	1303	214	62
SX, SN, SD8 125-08	2703	1303	1233	214	69
SX, SN, SD8 125-09	2908	1525	1383	230	76
SX, SN, SD8 125-10	3233	1650	1583	270	83
SX, SN, SD8 125-11	3358	1775	1583	270	90
SX, SN, SD8 125-12	3633	1900	1733	300	97
SX, SN, SD8 125-13	3758	2025	1733	300	104

Performance table

Model	Driving motor		l/m	Flow rate (Q)											
	(kW)	(hp)		0	1600	1800	2000	2200	2400	2600	2800	3000	3200		
				l/sec	0	26,67	30	33,33	36,67	40	43,33	46,67	50	53,33	
SX, SN, SD8 145-01	9,20	12,5	25	20	19	19	18	17	17	16	14	12			
SX, SN, SD8 145-02	18,50	25	50	40	39	38	36	35	33	31	28	24			
SX, SN, SD8 145-03	30	40	75	60	58	56	54	52	50	47	41	36			
SX, SN, SD8 145-04	37	50	100	80	77	75	72	70	66	62	55	48			
SX, SN, SD8 145-05	55	75	125	100	97	94	91	87	83	78	69	60			
SX, SN, SD8 145-06	55	75	150	120	116	113	109	104	100	93	83	72			
SX, SN, SD8 145-07	66	90	175	140	135	132	127	122	116	109	97	84			
SX, SN, SD8 145-08	75	100	200	160	154	150	145	139	133	124	110	96			
SX, SN, SD8 145-09	92	125	225	180	174	169	163	157	149	140	124	108			
SX, SN, SD8 145-10	110	150	250	200	193	188	181	174	166	155	138	120			
SX, SN, SD8 145-11	110	150	275	220	212	207	199	191	183	171	152	132			
SX, SN, SD8 145-12	110	150	300	240	232	226	217	209	199	186	166	144			

Size and weight

Model	Size (mm)				Weight (kg)
	A	B	C	M	
SX, SN, SD8 145-01	1301	550	751	60	20
SX, SN, SD8 145-02	1691	700	991	83	28
SX, SN, SD8 145-03	2101	850	1251	108	35
SX, SN, SD8 145-04	2341	1000	1341	118	43
SX, SN, SD8 145-05	2383	1150	1233	200	50
SX, SN, SD8 145-06	2533	1300	1233	200	58
SX, SN, SD8 145-07	2753	1450	1303	214	65
SX, SN, SD8 145-08	2983	1600	1383	230	73
SX, SN, SD8 145-09	3333	1750	1583	270	80
SX, SN, SD8 145-10	3633	1900	1733	300	88
SX, SN, SD8 145-11	3783	2050	1733	300	95
SX, SN, SD8 145-12	3933	2200	1733	300	103

SX, SN, SD 10 205

Performance curve ISO9906 Annex A 2850rpm

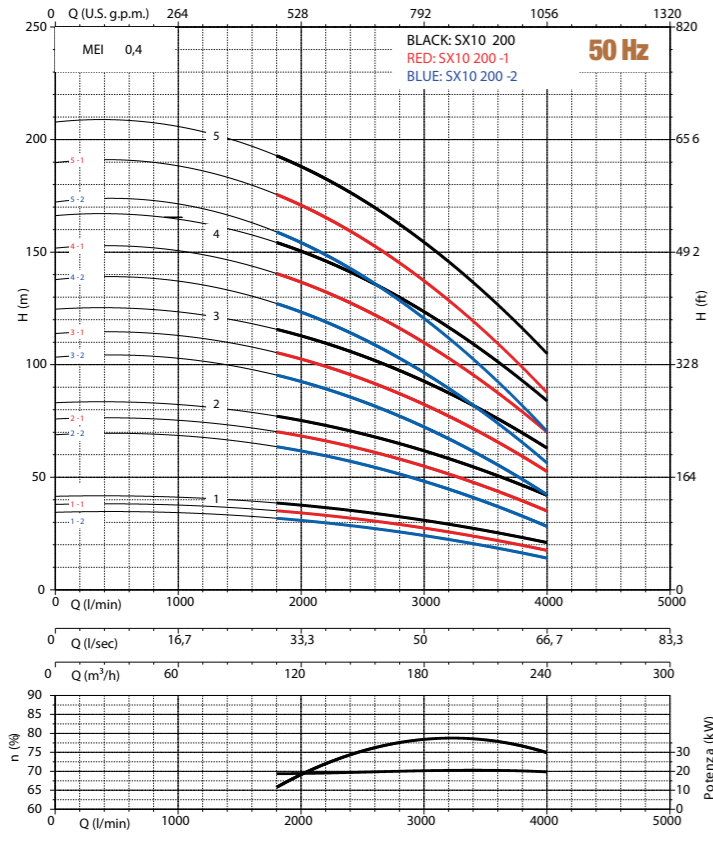

NPSH (m)	25%	50%	75%	100%
SX10 200	3,45	7,8	11,8	

Installation sketch

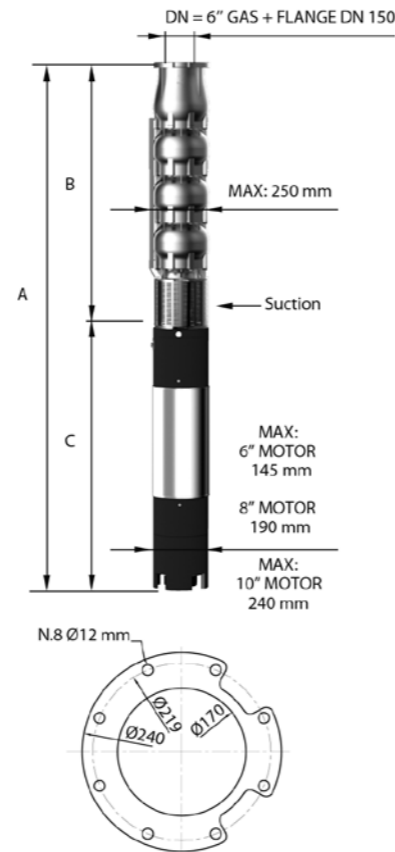

FOR COMMERCIAL TUBE
EXTERNAL DIAMETER: 168,3 mm

Size and weight

Model	Size (mm)				Weight (kg)
	A	B	C	M	
SX, SN, SD10 205-1-2	1616	625	991	83	41
SX, SN, SD10 205-1-1	1616	625	991	83	41
SX, SN, SD10 205-1	1696	625	1071	92	41
SX, SN, SD10 205-2-1	2146	805	1341	118	56
SX, SN, SD10 205-2-2	2146	805	1341	118	56
SX, SN, SD10 205-2	1928	805	1123	178	56
SX, SN, SD10 205-3-1	2218	985	1233	200	72
SX, SN, SD10 205-3-2	2218	985	1233	200	72
SX, SN, SD10 205-3	2288	985	1303	214	72
SX, SN, SD10 205-4-1	2468	1165	1303	214	87
SX, SN, SD10 205-4-2	2548	1165	1383	230	87
SX, SN, SD10 205-4	2748	1165	1583	270	87
SX, SN, SD10 205-5-1	2928	1345	1583	270	103
SX, SN, SD10 205-5-2	2928	1345	1583	270	103
SX, SN, SD10 205-5	3078	1345	1733	300	103

Performance table

Model	Driving motor		l/m	0	1800	2200	2600	3000	3400	3800	4000
	(kW)	(hp)									
	l/sec	0									
SX, SN, SD10 205-1-2	18,50	25		35	32	30	27	24	21	16	14
SX, SN, SD10 205-1-1	18,50	25		38	35	33	31	28	24	20	17
SX, SN, SD10 205-1	22	30		42	38	36	34	31	28	23	21
SX, SN, SD10 205-2-2	37	50		69	63	60	55	49	41	33	28
SX, SN, SD10 205-2-1	37	50		76	70	66	61	55	48	40	35
SX, SN, SD10 205-2	44	60		83	77	73	68	62	55	47	41
SX, SN, SD10 205-3-2	55	75		104	95	89	82	73	62	49	42
SX, SN, SD10 205-3-1	55	75		114	105	99	92	83	72	59	52
SX, SN, SD10 205-3	66	90		125	115	109	102	93	83	70	62
SX, SN, SD10 205-4-2	66	90		138	126	119	110	98	82	66	56
SX, SN, SD10 205-4-1	75	100		152	140	132	122	110	96	79	70
SX, SN, SD10 205-4	92	125		166	154	146	136	124	110	94	82
SX, SN, SD10 205-5-2	92	125		173	158	149	137	122	103	82	70
SX, SN, SD10 205-5-1	92	125		190	175	165	153	138	120	99	87
SX, SN, SD10 205-5	110	150		208	192	182	170	155	138	117	103

SX, SN, SD 10 205

Performance curve ISO9906 Annex A 2850rpm

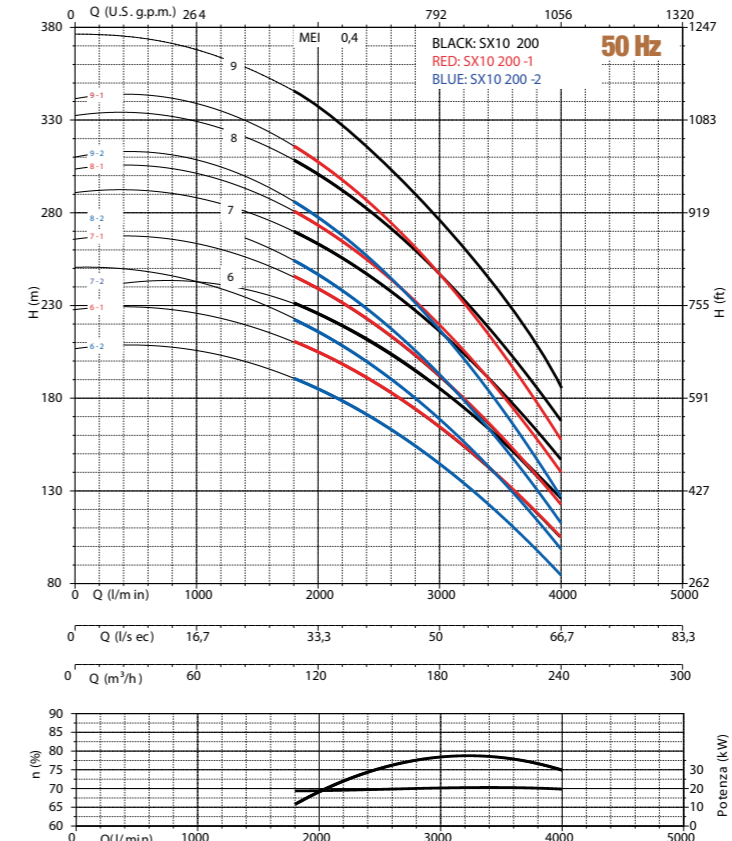

NPSH (m)	25%	50%	75%	100%
SX10 200	3,45	7,8	11,8	

Installation sketch

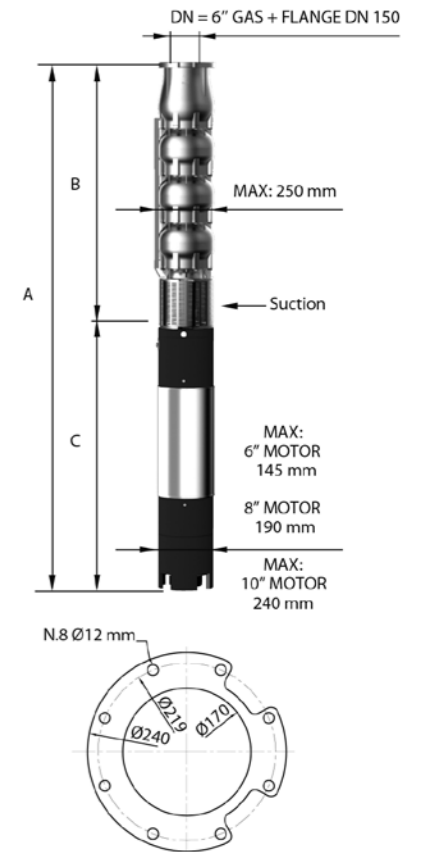

FOR COMMERCIAL TUBE
EXTERNAL DIAMETER: 168,3 mm

Performance table

Model	Driving motor		l/m	0	1800	2200	2600	3000	3400	3800	4000
	(kW)	(hp)									
	l/sec	0									
SX, SN, SD10 205-6-2	110	150		208	190	179	164	146	124	98	84
SX, SN, SD10 205-6-1	110	150		228	210	198	184	166	144	119	104
SX, SN, SD10 205-6	129	175		250	230	218	204	186	166	140	124
SX, SN, SD10 205-7-2	110	150		242	221	209	192	171	144	115	98
SX, SN, SD10 205-7-1	129	175		266	245	231	214	193	168	139	122
SX, SN, SD10 205-7	147	200		291	269	255	238	217	193	164	144
SX, SN, SD10 205-8-2	129	175		277	253	238	219	195	165	131	112
SX, SN, SD10 205-8-1	147	200		304	280	264	245	221	192	158	139
SX, SN, SD10 205-8	165	225		333	307	291	272	248	221	187	165
SX, SN, SD10 205-9-2	147	200		311	284	268	247	220	185	148	126
SX, SN, SD10 205-9-1	165	225		342	315	297	275	248	216	178	157
SX, SN, SD10 205-9	185	250		374	346	328	306	279	248	211	185

Size and weight

Model	Size (mm)				Weight (kg)
	A	B	C	M	
SX, SN, SD10 205-6-2	3258	1525	1773	300	118
SX, SN, SD10 205-6-1	3258	1525	1773	300	118
SX, SN, SD10 205-6	3259	1525	1634	385	118
SX, SN, SD10 205-7-2	3438	1705	1773	300	134
SX, SN, SD10 205-7-1	3339	1705	1634	385	134
SX, SN, SD10 205-7	3439	1705	1734	415	134
SX, SN, SD10 205-8-2	3519	1885	1634	385	149
SX, SN, SD10 205-8-1	3619	1885	1734	415	149
SX, SN, SD10 205-8	3739	1885	1854	444	149
SX, SN, SD10 205-9-2	3799	2065	1734	415	165
SX, SN, SD10 205-9-1	3919	2065	1854	444	165
SX, SN, SD10 205-9	4049	2065	1984	480	165

SX SN SD 10 225

Performance curve ISO9906 Annex A 2850rpm

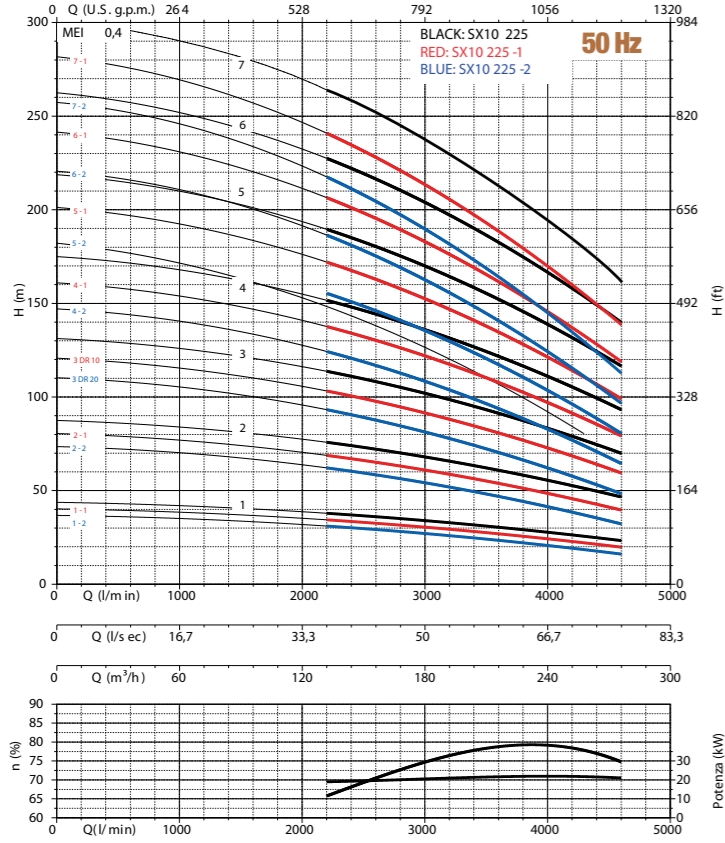

NPSH (m)	25%	50%	75%	100%
SX10 225	3,45	7,8	11,8	

Installation sketch

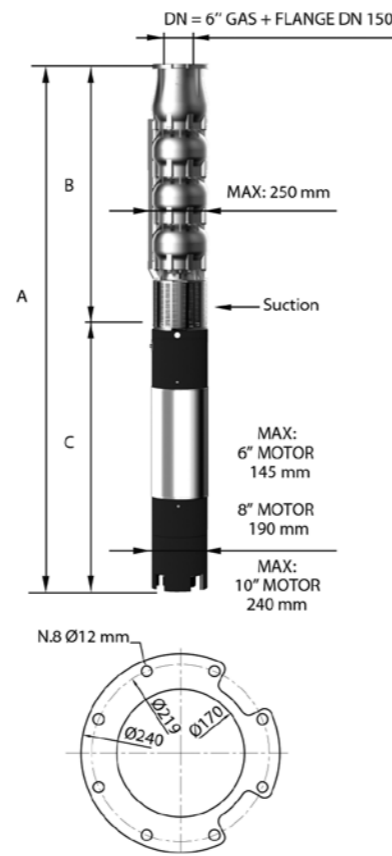

FOR COMMERCIAL TUBE
EXTERNAL DIAMETER: 168,3 mm

SX, SN, SD 10 245

Performance curve ISO9906 Annex A 2850rpm

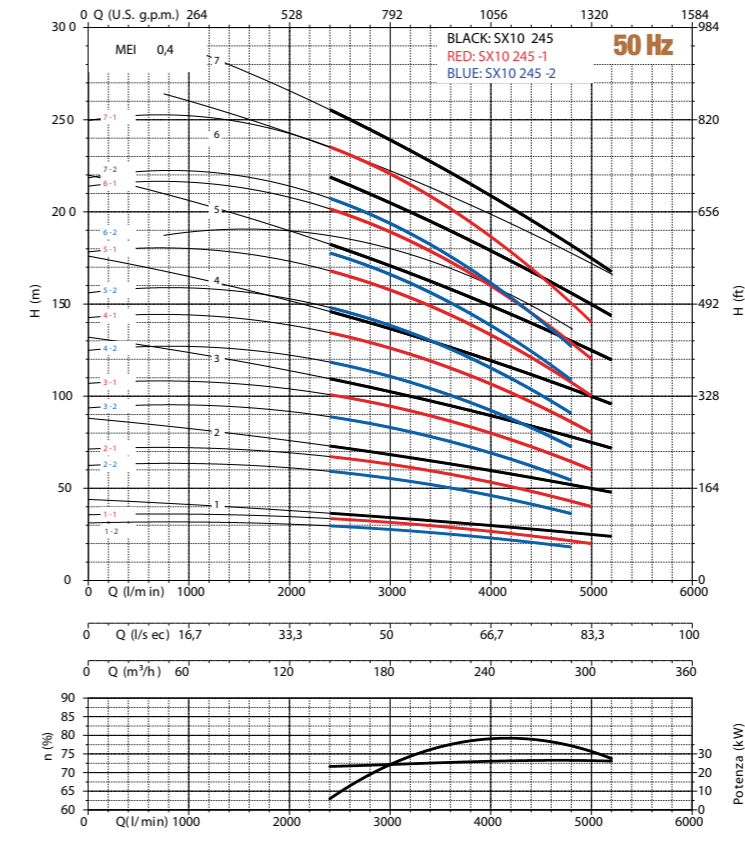

NPSH (m)	25%	50%	75%	100%
SX10 245	3,45	7,8	11,8	

Installation sketch

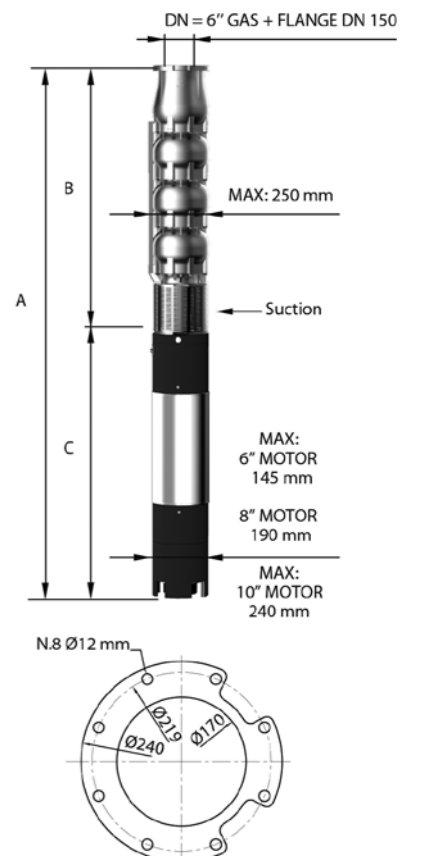

FOR COMMERCIAL TUBE
EXTERNAL DIAMETER: 168,3 mm

Performance table

Model	Driving motor		l/m	0	2200	2600	3000	3400	3800	4200	4600
	(kW)	(hp)									
		m³/h	0	132	156	180	204	228	252	276	
SX, SN, SD10 225-1-2	18,50	25		37	31	29	27	25	23	19	16
SX, SN, SD10 225-1-1	22	30		40	34	33	31	29	26	23	20
SX, SN, SD10 225-1	22	30		44	38	36	34	32	30	26	23
SX, SN, SD10 225-2-2	37	50		74	62	58	54	50	45	38	32
SX, SN, SD10 225-2-1	44	60		81	68	65	61	57	52	46	39
SX, SN, SD10 225-2	44	60		88	75	72	68	64	59	53	46
SX, SN, SD10 225-3-2	55	75		110	93	87	81	75	68	57	48
SX, SN, SD10 225-3-1	66	90		121	102	98	92	86	78	68	59
SX, SN, SD10 225-3	75	100		131	113	108	102	96	89	79	69
SX, SN, SD10 225-4-2	75	100		147	124	116	108	100	90	76	64
SX, SN, SD10 225-4-1	92	125		162	136	130	122	114	104	91	78
SX, SN, SD10 225-4	92	125		175	150	144	136	128	118	106	92
SX, SN, SD10 225-5-2	92	125		184	155	145	135	125	113	95	80
SX, SN, SD10 225-5-1	110	150		202	170	163	153	143	130	114	98
SX, SN, SD10 225-5	129	175		219	188	180	170	160	148	132	115
SX, SN, SD10 225-6-2	110	150		221	186	174	162	150	136	114	96
SX, SN, SD10 225-6-1	129	175		242	204	196	184	172	156	137	118
SX, SN, SD10 225-6	147	200		263	226	216	204	192	178	158	138
SX, SN, SD10 225-7-2	129	175		258	217	203	189	175	158	133	112
SX, SN, SD10 225-7-1	147	200		283	238	228	214	200	182	160	137
SX, SN, SD10 225-7	165	225		307	263	252	238	224	207	185	161

Size and weight

Model	Size (mm)				Weight (kg)
	A	B	C	M	
SX,SN,SD10 225-1-2	1616	625	991	83	41
SX,SN,SD10 225-1-1	1696	625	1071	92	41
SX,SN,SD10 225-1	1696	625	1071	92	41
SX,SN,SD10 225-2-2	2146	805	1341	118	56
SX,SN,SD10 225-2-1	1928	805	1123	178	56
SX,SN,SD10 225-2	1928	805	1123	178	56
SX,SN,SD10 225-3-2	2218	985	1233	200	72
SX,SN,SD10 225-3-1	2288	985	1303	214	72
SX,SN,SD10 225-3	2368	985	1383	230	72
SX,SN,SD10 225-4-2	2548	1165	1383	230	87
SX,SN,SD10 225-4-1	2748	1165	1583	270	87
SX,SN,SD10 225-4	2748	1165	1583	270	87
SX,SN,SD10 225-5-2	2928	1345	1583	270	103
SX,SN,SD10 225-5-1	3078	1345	1733	300	103
SX,SN,SD10 225-5	2979	1345	1634	385	103
SX,SN,SD10 225-6-2	3258	1525	1733	300	118
SX,SN,SD10 225-6-1	3159	1525	1634	385	118
SX,SN,SD10 225-6	3259	1525	1734	415	118
SX,SN,SD10 225-7-2	3339	1705	1634	385	134
SX,SN,SD10 225-7-1	3439	1705	1734	415	134
SX,SN,SD10 225-7	3559	1705	1854	444	134

Performance table

Model	Driving motor		l/m	0	2400	2800	3200	3600	4000	4400	4800	5000	5200
	(kW)	(hp)											
		m³/h	0	144	168	192	216	240	264	288	300	312	
SX, SN, SD10 245-1-2	18,50	25		31	29	28	27	25	23	21	18		
SX, SN, SD10 245-1-1	22	30		36	33	32	31	29	27	24	22	20	
SX, SN, SD10 245-1	30	40		44	37	35	34	32	30	28	26	25	24
SX, SN, SD10 245-2-2	37	50		62	58	56	54	50	46	42	36		
SX, SN, SD10 245-2-1	44	60		72	66	64	62	58	54	48	44	40	
SX, SN, SD10 245-2	55	75		88	73	69	67	64	59	56	52	50	48
SX, SN, SD10 245-3-2	55	75		94	88	85	81	76	70	63	53		
SX, SN, SD10 245-3-1	66	90		107	100	97	93	86	80	73	65	59	
SX, SN, SD10 245-3	92	125		132	110	104	101	96	89	83	78	75	72
SX, SN, SD10 245-4-2	75	100		125	117	113	108	101	93	84	71		
SX, SN, SD10 245-4-1	92	125		143	133	129	124	115	107	97	87	79	
SX, SN, SD10 245-4	110	150		176	146	138	134	128	118	111	104	100	96
SX, SN, SD10 245-5-2	92	125		156	146	141	135	126	116	105	89		
SX, SN, SD10 245-5-1	110	150		179	166	161	155	144	134	121	109	99	
SX, SN, SD10 245-5	147	200		220	183	173	168	160	148	139	130	125	120
SX, SN, SD10 245-6-2	110	150		187	175	169	162	151	139	126	107		
SX, SN, SD10 245-6-1	147	200		215	199	193	186	173	161	145	131	119	
SX, SN, SD10 245-6	165	225		264	220	208	202	192	178	167	156	150	144
SX, SN, SD10 245-7-2	129	175		218	204	197	189	176	162	147	125		
SX, SN, SD10 245-7-1	165	225		251	232	225	217	202	188	169	153	139	
SX, SN, SD10 245-7	220	300		308	256	242	235	224	207	195	182	175	168

Size and weight

Model	Size (mm)				Weight (kg)
	A	B	C	M	
SX,SN,SD10 245-1-2	1616	625	991	83	41
SX,SN,SD10 245-1-1	1696	625	1071	92	41
SX,SN,SD10 245-1	1876	625	1251	108	41
SX,SN,SD10 245-2-2	2146	805	1341	118	56
SX,SN,SD10 245-2-1	1928	805	1123	178	56
SX,SN,SD10 245-2	2038	805	1233	200	56
SX,SN,SD10 245-3-2	2218	985	1233	200	72
SX,SN,SD10 245-3-1	2288	985	1303	214	72
SX,SN,SD10 245-3	2568	985	1583	270	72
SX,SN,SD10 245-4-2	2548	1165	1383	230	87
SX,SN,SD10 245-4-1	2748	1165	1583	270	87
SX,SN,SD10 245-4	2898	1165	1733	300	87
SX,SN,SD10 245-5-2	2928	1345	1583	270	103
SX,SN,SD10 245-5-1	3078	1345	1733	300	103
SX,SN,SD10 245-5	3079	1345	1734	415	103
SX,SN,SD10 245-6-2	3258	1525	1733	300	118
SX,SN,SD10 245-6-1	3259	1525	1734	415	118
SX,SN,SD10 245-6	3379	1525	1854	444	118
SX,SN,SD10 245-7-2	3339	1705	1634	385	134
SX,SN,SD10 245-7-1	3559	1705	1854	444	134
SX,SN,SD10 245-7	0	1705	0	0	134

SX SN SD 10 275

Performance curve ISO9906 Annex A 2850rpm

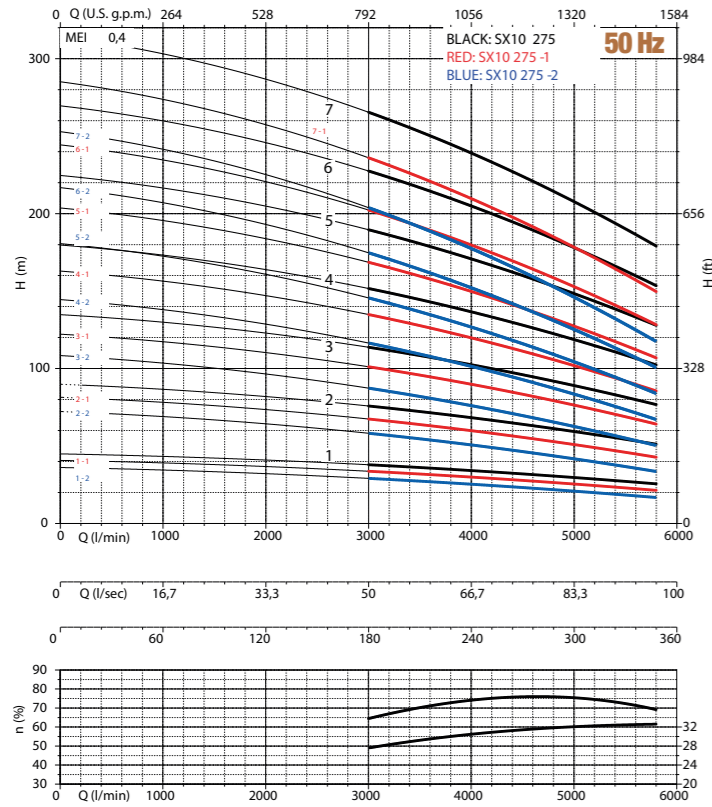

NPSH (m)	25%	50%	75%	100%
SX10 275	3,45	7,8	11,8	

Installation sketch

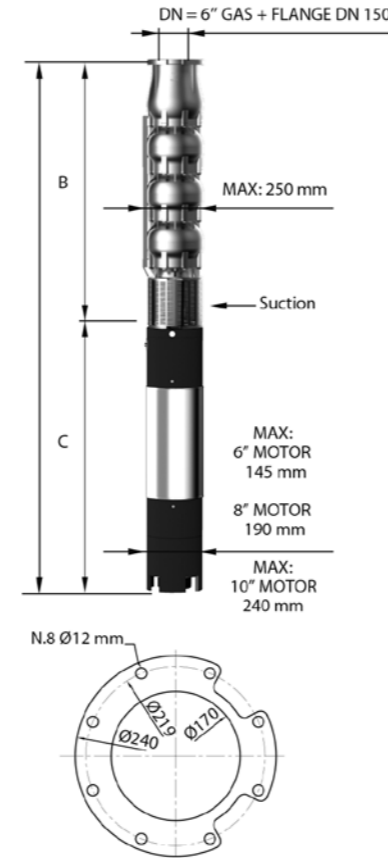

FOR COMMERCIAL TUBE
EXTERNAL DIAMETER: 168,3 mm

SX, SN, SD 12 365

Performance curve ISO9906 Annex A 2850rpm

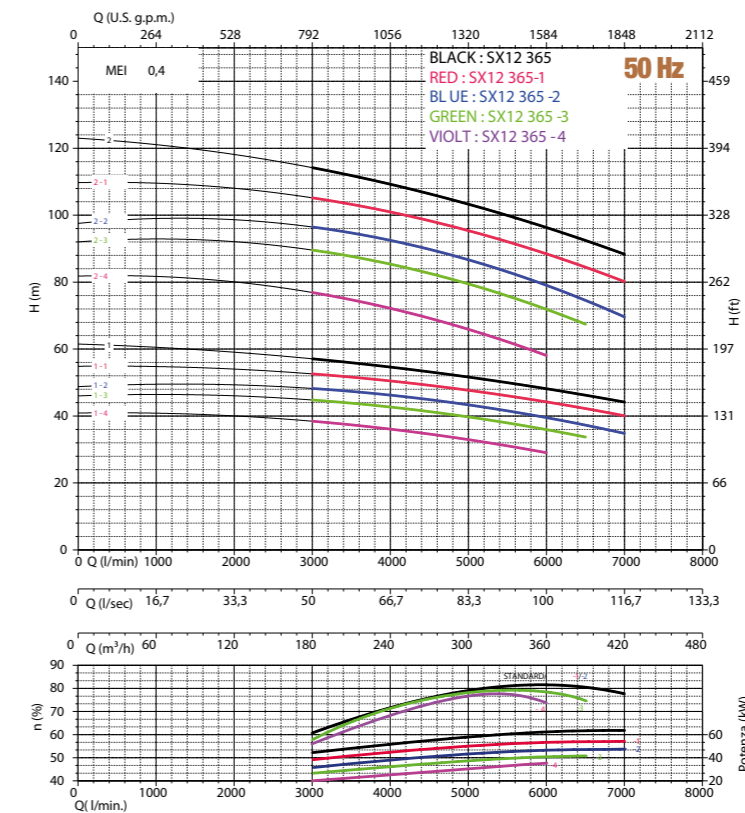

NPSH (m)	25%	50%	75%	100%
SX12 365	3,45	7,8	11,8	

Installation sketch

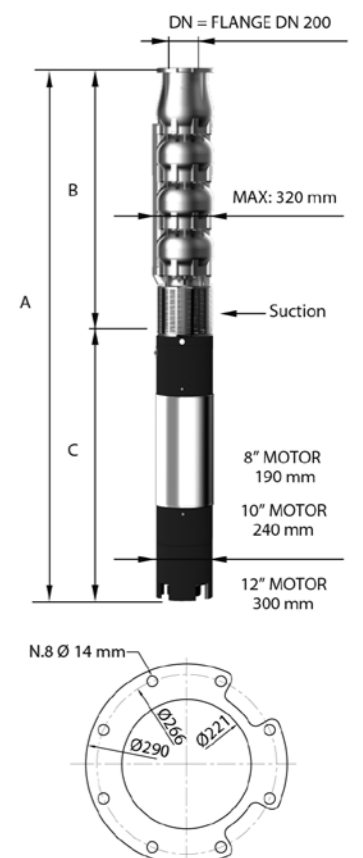

FOR COMMERCIAL TUBE
EXTERNAL DIAMETER: 219,1 mm

Performance table

Model	Driving motor		l/m	H (m)										
	(kW)	(hp)		0	3000	3400	3800	4200	4600	5000	5400	5800		
				l/sec	0	50	56,67	63,33	70	76,67	83,33	90	96,67	
				m³/h	0	180	204	228	252	276	300	324	348	
SX, SN, SD10 275-1-2	26	35	36	29	28	26	25	23	21	19	16			
SX, SN, SD10 275-1-1	30	40	41	33	32	31	29	27	26	24	21			
SX, SN, SD10 275-1	44	60	45	38	37	35	34	32	30	28	25			
SX, SN, SD10 275-2-2	55	75	72	58	56	52	50	46	42	39	32			
SX, SN, SD10 275-2-1	66	90	82	67	65	62	59	55	52	48	42			
SX, SN, SD10 275-2	66	90	90	75	73	70	67	63	60	56	50			
SX, SN, SD10 275-3-2	75	100	109	86	83	79	74	68	64	58	49			
SX, SN, SD10 275-3-1	92	125	122	100	97	92	88	82	77	72	62			
SX, SN, SD10 275-3	110	150	135	113	110	105	101	95	90	85	75			
SX, SN, SD10 275-4-2	110	150	145	115	111	105	99	91	85	78	65			
SX, SN, SD10 275-4-1	129	175	163	134	130	123	118	110	103	96	83			
SX, SN, SD10 275-4	129	175	180	150	146	140	134	126	120	113	100			
SX, SN, SD10 275-5-2	129	175	181	144	139	131	124	114	106	97	81			
SX, SN, SD10 275-5-1	147	200	204	167	162	154	147	137	129	120	104			
SX, SN, SD10 275-5	165	225	225	188	183	175	168	158	150	141	125			
SX, SN, SD10 275-6-2	147	200	217	173	167	157	149	137	127	116	97			
SX, SN, SD10 275-6-1	185	250	245	200	194	185	176	164	155	144	125			
SX, SN, SD10 275-6	220	300	270	226	220	210	202	190	180	169	150			
SX, SN, SD10 275-7-2	185	250	253	202	195	183	174	160	148	136	113			
SX, SN, SD10 275-7-1	220	300	286	234	227	216	206	192	181	168	146			
SX, SN, SD10 275-7	250	340	315	263	256	245	235	221	210	197	175			

Size and weight

Model	Size (mm)				Weight (kg)
	A	B	C	M	
SX,SN,SD10 275-1-2	1806	625	1181	100	41
SX,SN,SD10 275-1-1	1876	625	1251	108	41
SX,SN,SD10 275-1	1748	625	1123	178	41
SX,SN,SD10 275-2-2	2038	805	1233	200	56
SX,SN,SD10 275-2-1	2108	805	1303	214	56
SX,SN,SD10 275-2	2108	805	1303	214	56
SX,SN,SD10 275-3-2	2368	985	1383	230	72
SX,SN,SD10 275-3-1	2568	985	1583	270	72
SX,SN,SD10 275-3	2718	985	1733	300	72
SX,SN,SD10 275-4-2	2898	1165	1733	300	87
SX,SN,SD10 275-4-1	2799	1165	1634	385	87
SX,SN,SD10 275-4	2799	1165	1634	385	87
SX,SN,SD10 275-5-2	2979	1345	1634	385	103
SX,SN,SD10 275-5-1	3079	1345	1734	415	103
SX,SN,SD10 275-5	3199	1345	1854	444	103
SX,SN,SD10 275-6-2	3259	1525	1734	415	118
SX,SN,SD10 275-6-1	3509	1525	1984	480	118
SX,SN,SD10 275-6	0	1525	0	0	118
SX,SN,SD10 275-7-2	0	1705	0	0	134
SX,SN,SD10 275-7-1	0	1705	0	0	134
SX,SN,SD10 275-7	0	1705	0	0	134

Performance table

Model	Driving motor		l/m	H (m)										
	(kW)	(hp)		0	3000	3500	4000	4500	5000	5500	6000	6500	7000	
				l/sec	0	50	58,33	66,67	75	83,33	91,67	100	108,33	116,67
				m³/h	0	180	210	240	270	300	330	360	390	420
SX, SN, SD12 365-1-4	37	50	41	38	37	37	35	33	32	29				
SX, SN, SD12 365-1-3	44	60	46	45	44	43	42	39	38	36	34			
SX, SN, SD12 365-1-2	55	75	49	48	47	47	45	44	42	40	38	34		
SX, SN, SD12 365-1-1	55	75	55	52	52	51	50	48	47	44	42	40		
SX, SN, SD12 365-1	66	90	62	56	55	55	53	52	52	50	47	42		
SX, SN, SD12 365-2-4	75	100	82	76	74	73	70	66	63	57	50	48		
SX, SN, SD12 365-2-3	92	125	92	89	88	86	84	78	75	72	68			
SX, SN, SD12 365-2-2	110	150	98	95	94	93	90	87	84	80	75	68		
SX, SN, SD12 365-2-1	110	150	110	104	103	101	99	96	93	88	84	80		
SX, SN, SD12 365-2	129	175	124	112	110	109	106	104	103	100	93	84		

Size and weight

Model	Size (mm)				Weight (kg)
	A	B	C	M	
SX,SN,SD12 365-1-4	1813	770	1043	160	79
SX,SN,SD12 365-1-3	1893	770	1123	178	79
SX,SN,SD12 365-1-2	2003	770	1233	200	79
SX,SN,SD12 365-1-1	2003	770	1233	200	79
SX,SN,SD12 365-1	2073	770	1303	214	79
SX,SN,SD12 365-2-4	2383	1000	1383	230	104
SX,SN,SD12 365-2-3	2583	1000	1583	270	104
SX,SN,SD12 365-2-2	2733	1000	1733	300	104
SX,SN,SD12 365-2-1	2504	1000	1504	350	104
SX,SN,SD12 365-2	2634	1000	1634	385	104

SX SN SD 12 365

Performance curve ISO9906 Annex A 2850rpm

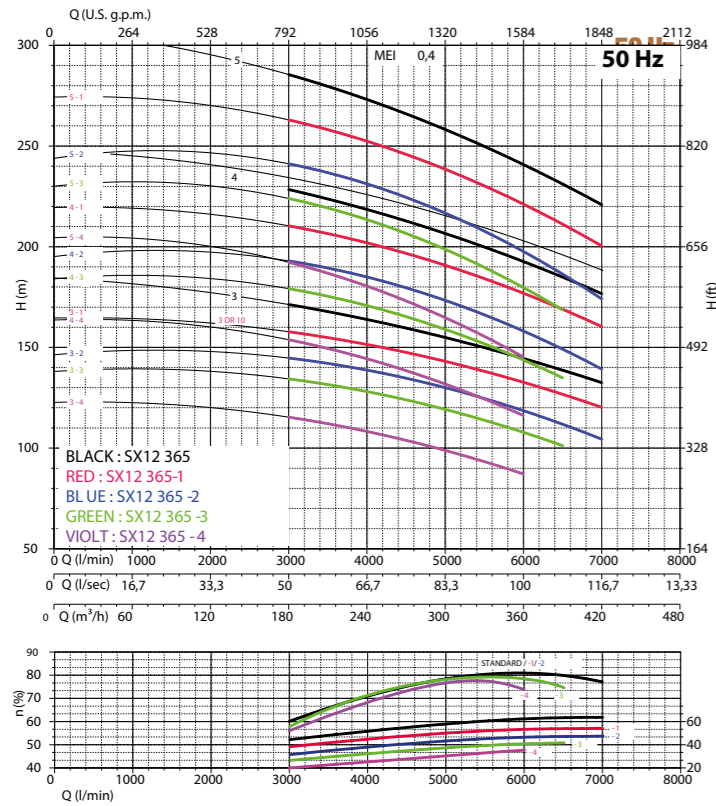

NPSH (m)	25%	50%	75%	100%
SX12 365	3,45	7,8	11,8	

Installation sketch

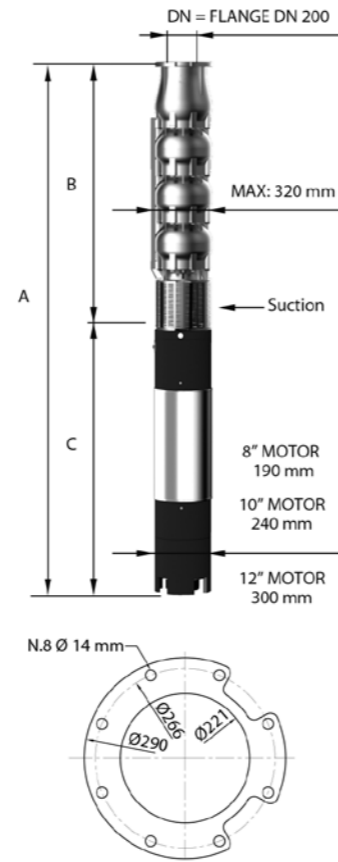

FOR COMMERCIAL TUBE
EXTERNAL DIAMETER: 219,1 mm

Performance table

Model	Driving motor		H (m)	Flow rate (Q)											
	(kW)	(hp)		l/m	0	3000	3500	4000	4500	5000	5500	6000	6500	7000	
				l/sec	0	50	58,33	66,67	75	83,33	91,67	100	108,33	116,67	
				m³/h	0	180	210	240	270	300	330	360	390	420	
SX, SN, SD12 365-3-4	110	150	123	114	111	110	105	99	95	86					
SX, SN, SD12 365-3-3	129	175	138	134	132	129	126	117	113	108	102				
SX, SN, SD12 365-3-2	147	200	147	143	141	140	135	131	126	120	113	102			
SX, SN, SD12 365-3-1	165	225	165	156	155	152	149	144	140	132	126	120			
SX, SN, SD12 365-3	220	300	186	168	165	164	159	156	155	150	140	126			
SX, SN, SD12 365-4-4	147	200	164	152	148	146	140	132	126	114	50	50			
SX, SN, SD12 365-4-3	185	250	184	178	176	172	168	156	150	144	136	49			
SX, SN, SD12 365-4-2	220	300	196	190	188	186	180	174	168	160	150	136			
SX, SN, SD12 365-4-1	220	300	220	208	206	202	198	192	186	176	168	160			
SX, SN, SD12 365-4	250	340	248	224	220	218	212	208	206	200	186	168			
SX, SN, SD12 365-5-4	185	250	205	190	185	183	175	165	158	143	83	83			
SX, SN, SD12 365-5-3	220	300	230	223	220	215	210	195	188	180	170	100			
SX, SN, SD12 365-5-2	250	340	245	238	235	233	225	218	210	200	188	170			
SX, SN, SD12 365-5-1	300	408	275	260	258	253	248	240	233	220	210	200			
SX, SN, SD12 365-5	350	475	310	280	275	273	265	260	258	250	233	210			

Size and weight

Model	Size (mm)				Weight (kg)
	A	B	C	M	
SX,SN,SD12 365-3-4	2963	1230	1733	300	129
SX,SN,SD12 365-3-3	2864	1230	1634	385	129
SX,SN,SD12 365-3-2	2964	1230	1734	415	129
SX,SN,SD12 365-3-1	3084	1230	1854	444	129
SX,SN,SD12 365-3	3123	1230	1893	663	129
SX,SN,SD12 365-4-4	2964	1230	1734	415	129
SX,SN,SD12 365-4-3	3214	1230	1984	480	129
SX,SN,SD12 365-4-2	0	1230	0	0	129
SX,SN,SD12 365-4-1	0	1230	0	0	129
SX, SN, SD12 365-4	0	1230	0	0	129
SX,SN,SD12 365-5-4	3674	1690	1984	480	179
SX,SN,SD12 365-5-3	0	1690	0	0	179
SX,SN,SD12 365-5-2	0	1690	0	0	179
SX,SN,SD12 365-5-1	0	1690	0	0	179
SX, SN, SD12 365-5	0	1690	0	0	179

SX, SN, SD 12 445

Performance curve ISO9906 Annex A 2850rpm

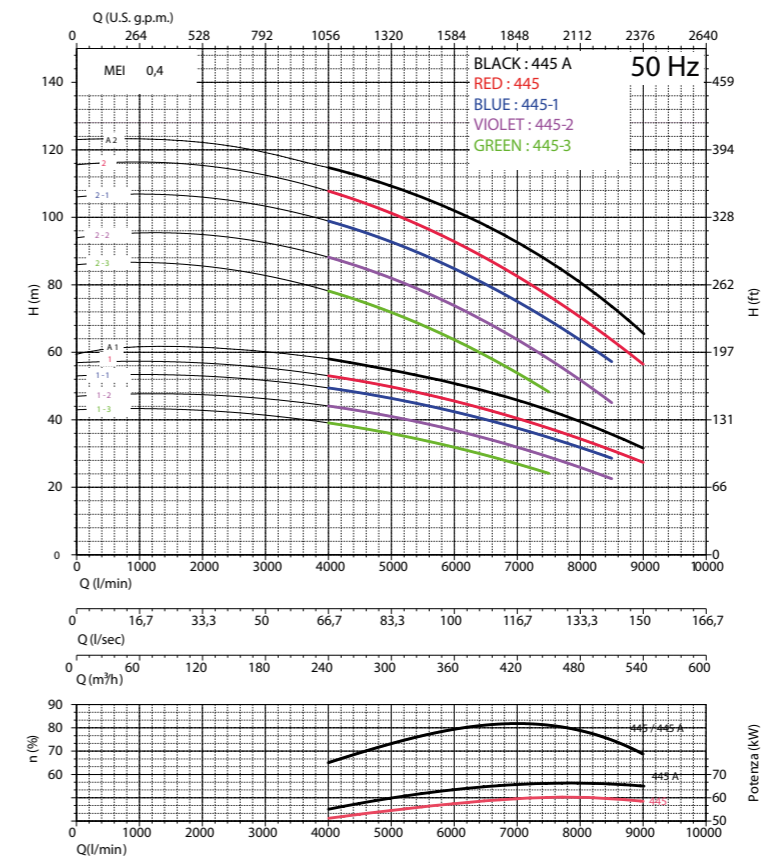

NPSH (m)	25%	50%	75%	100%
SX12 445	3,45	7,8	11,8	

Installation sketch

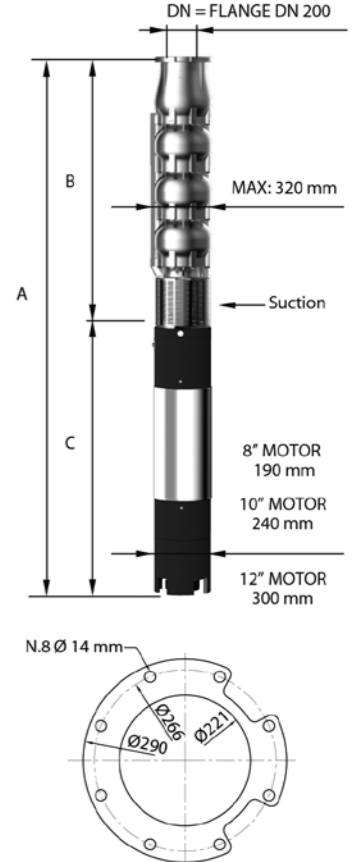

FOR COMMERCIAL TUBE
EXTERNAL DIAMETER: 219,1 mm

Performance table

Model	Driving motor		H (m)	Flow rate (Q)												
	(kW)	(hp)		l/m	0	4000	4500	5000	5500	6000	6500	7000	7500	8000	8500	9000
				l/sec	0	66,67	75	83,33	91,67	100	108,33	116,67	25	133,33	141,67	150
				m³/h	0	240	270	300	330	360	390	420	450	480	510	540
SX, SN, SD12 445-1-3	37	50	43	39	38	36	34	32	30	27	24					
SX, SN, SD12 445-1-2	44	60	47	44	43	41	39	37	35	33	30	26	22			
SX, SN, SD12 445-1-1	55	75	53	50	48	46	44	42	40	38	36	32	28			
SX, SN, SD12 445-1	66	90	58	54	52	50	48	46	44	42	40	37	31	27		
SX, SN, SD12 445 A-1	66	90	61	57	54	53	52	50	48	46	44	41	39	32		
SX, SN, SD12 445-2-3	75	100	86	78	76	72	68	64	60	54	48					
SX, SN, SD12 445-2-2	92	125	94	88	86	82	77	73	69	65	59	52	44			
SX, SN, SD12 445-2-1	110	150	106	100	96	92	88	84	80	76	71	64	56			
SX, SN, SD12 445-2	129	175	116	108	104	100	96	92	88	84	80	73	62	54		
SX, SN, SD12 445 A-2	147	200	122	114	108	106	104	100	96	92	89	82	78	64		

Size and weight

Model	Size (mm)				Weight (kg)
	A	B	C	M	
SX,SN,SD12 445-1-3	1813	770	1043	160	79
SX,SN,SD12 445-1-2	1893	770	1123	178	79
SX,SN,SD12 445-1-1	2003	770	1233	200	79
SX,SN,SD12 445-1	2073	770	1303	214	79
SX,SN,SD12 445 A-1	2073	770	1303	214	79

Model	Size (mm)				Weight (kg)
	A	B	C	M	
SX,SN,SD12 445-2-3	2383	1000	1383	230	104
SX,SN,SD12 445-2-2	2583	1000	1583	270	104
SX,SN,SD12 445-2-1	2733	1000	1733	300	104
SX,SN,SD12 445-2	2634	1000	1634	385	104
SX,SN,SD12 445 A2	2734	1000	1734	415	104

SX SN SD 12 445

Performance curve ISO9906 Annex A 2850rpm

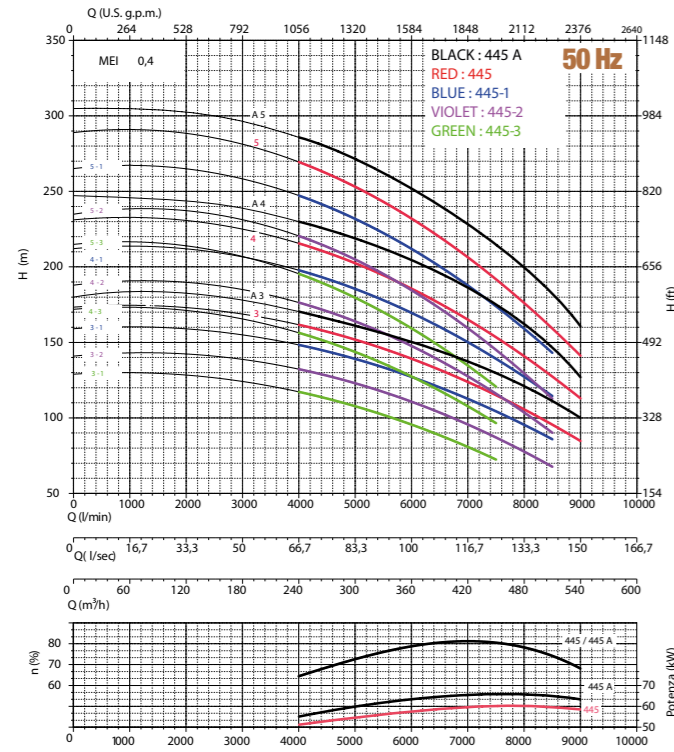

Installation sketch

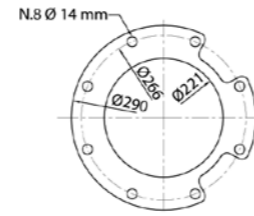
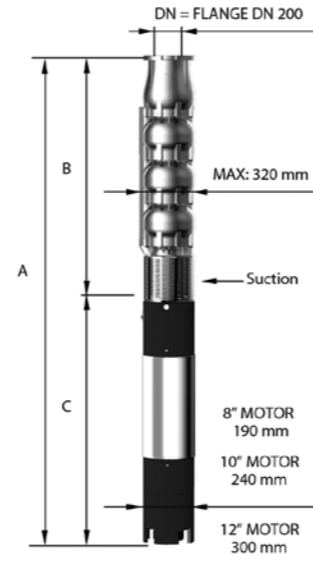

FOR COMMERCIAL TUBE
EXTERNAL DIAMETER: 219,1 mm

Performance table

Model	Driving motor		l/m	Flow rate (Q)														
	(kW)	(hp)		0	4000	4500	5000	5500	6000	6500	7000	7500	8000	8500	9000			
				l/sec	66,67	75	83,33	91,67	100	108,33	116,67	125	133,33	141,67	150			
			m³/h	0	240	270	300	330	360	390	420	450	480	510	540			
SX, SN, SD12 445-3-3	129	175	H (m)	129	117	113	108	102	96	89	81	72						
SX, SN, SD12 445-3-2	147	200		141	132	129	123	116	110	104	98	89	78	66				
SX, SN, SD12 445-3-1	165	225		159	150	144	138	132	126	120	114	107	96	84				
SX, SN, SD12 445-3	185	250		174	162	156	150	144	138	132	126	120	110	93	81			
SX, SN, SD12 445 A-3	220	300		183	171	162	159	156	150	144	138	134	123	117	96			
SX, SN, SD12 445-4-3	165	225		172	156	150	144	136	128	118	108	96						
SX, SN, SD12 445-4-2	185	250		188	176	172	164	154	146	138	130	118	104	88				
SX, SN, SD12 445-4-1	220	300		212	200	192	184	176	168	160	152	142	128	112				
SX, SN, SD12 445-4	250	340		232	216	208	200	192	184	176	168	160	146	124	108			
SX, SN, SD12 445 A-4	300	408		244	228	216	212	208	200	192	184	178	164	156	128			
SX, SN, SD12 445-5-3	220	300		215	195	188	180	170	160	148	135	120						
SX, SN, SD12 445-5-2	250	340		235	220	215	205	193	183	173	163	148	130	110				
SX, SN, SD12 445-5-1	300	408		265	250	240	230	220	210	200	190	178	160	140				
SX, SN, SD12 445-5	300	408		290	270	260	250	240	230	220	210	200	183	155	135			
SX, SN, SD12 445 A-5	350	475		305	285	270	265	260	250	240	230	223	205	195	160			

Size and weight

Model	Size (mm)				Weight (kg)
	A	B	C	M	
SX,SN,SD12 445-3-3	2864	1230	1634	385	129
SX,SN,SD12 445-3-2	2964	1230	1734	415	129
SX,SN,SD12 445-3-1	3084	1230	1854	444	129
SX,SN,SD12 445-3	3214	1230	1984	480	129
SX,SN,SD12 445 A-3	0	1230	0	0	129

Model	Size (mm)				Weight (kg)
	A	B	C	M	
SX,SN,SD12 445-4-3	3084	1230	1854	444	129
SX,SN,SD12 445-4-2	3214	1230	1984	480	129
SX,SN,SD12 445-4-1	0	1230	0	0	129
SX,SN,SD12 445-4	0	1230	0	0	129
SX,SN,SD12 445 A-4	0	1230	0	0	129

Model	Size (mm)				Weight (kg)
	A	B	C	M	
SX,SN,SD12 445-5-3	0	1690	0	0	179
SX,SN,SD12 445-5-2	0	1690	0	0	179
SX,SN,SD12 445-5-1	0	1690	0	0	179
SX,SN,SD12 445-5	0	1690	0	0	179
SX,SN,SD12 445 A-5	0	1690	0	0	179



HY04

4" Rewindable Oil filled Submersible motors



4" Rewindable Oil Filled Submersible Motors

Motors designed to work in 4" or wider wells. The use of very high quality materials and our strict tests together with consolidated know how ensure high mechanical resistance and high performing electric features.

All parts in contact with water are in AISI 304 stainless steel. The power cable with removable connector ensures perfect water-tightness.

Product features

External sleeve and bottom:

Made in AISI 304 stainless steel. More specifically, sleeve is made of AISI 304L (Low carbon) to avoid possible corrosions on the welding.

Upper Bracket:

Cast iron with cataphoresis treatment and protected with an AISI 304 stainless steel cover. Sleeve clamping is ensured by 4 inserts in low power motors and 6 inserts in motors bigger than 3Hp.

Mechanical Seal:

Graphite/ceramic in the standard version; SIC-SIC version available upon request.

Ball Bearings:

Duly oversized to ensure a long lasting motor.

Stator:

With 24 slots, specifically developed to achieve maximum electrical yield. Airtight sealed and immersed in selected mineral white and highly refined oil, suitable to be used in drinking water (F.D.A., Food and Drug Administration, approved).

Removable Power Cable-Connector:

It ensures perfect sealing in the most critical conditions and it aids maintenance operations. More specifically, the connector prevents oil from rising in the conductors up to the joint, thus enabling immersion at greater depths. The power cable complies with all major standards on the use in drinking water (KTW, ACS, WRAS).

Shaft:

Carbon-steel alloys in the rotor area, to foster electrical features. AISI 304 stainless steel projection. DUPLEX, a special type of stainless steel, replaces AISI 304 in motors bigger than 3Hp. This steel combines excellent resistance to corrosion and high mechanical resistance, which is necessary where static torque becomes really important.

100% tested:

All motors are tested at the end of the line. An extremely effective seal check is also carried out on all motors.



Single phase submersible motors 50Hz 230v oil filled

Type	P ₂ [Hp]	P ₂ [kW]	Voltage [V]	Ph	I _n [A]	I _{avv} [A]	rpm	φ cos	η [%]	Capacitor [μF]	Thrust load [N]	Length A [mm]	Weight [kg]	Cable section [mm ²]	Cable Length [m]
HYO4-037S230	0,5	0,37	230	1	3,6	12	2810	0,87	52	20	2000	311,3	6,45	4 x 1,5	1,7
HYO4-055S230	0,75	0,55	230	1	4,7	16,5	2810	0,88	57	25	2000	331,3	7,2	4 x 1,5	1,7
HYO4-075S230	1	0,75	230	1	5,9	18,9	2825	0,9	62	35	2000	356,3	8,45	4 x 1,5	1,7
HYO4-110S230	1,5	1,1	230	1	8,3	26,2	2840	0,91	64	40	2000	386,3	10,2	4 x 1,5	1,7
HYO4-150S230	2	1,5	230	1	10,7	35	2845	0,93	66	60	2000	436,3	11,65	4 x 1,5	1,7
HYO4-220S230	3	2,2	230	1	15,2	47	2820	0,93	67	80	2000	481,3	14,9	4 x 1,5	1,7
HYO4-370S230	5	3,7	230	1	24,5	95	2810	0,95	73	10+315/400	5000	699,5	24,15	4 x 2	2,7

Three phase submersible motors 50Hz 230V oil filled

Type	P ₂ [Hp]	P ₂ [kW]	Voltage [V]	Ph	I _n [A]	I _{avv} [A]	rpm	φ cos	η [%]	Capacitor [μF]	Thrust load [N]	Length A [mm]	Weight [kg]	Cable section [mm ²]	Cable Length [m]
HYO4-037T230	0,5	0,37	230	3	2,2	8,9	2855	0,75	57	-	2000	311,3	6,45	4 x 1,5	1,7
HYO4-055T230	0,75	0,55	230	3	3,4	13,5	2830	0,70	62	-	2000	331,3	7,2	4 x 1,5	1,7
HYO4-075T230	1	0,75	230	3	4,1	15,5	2820	0,74	62	-	2000	356,3	8,45	4 x 1,5	1,7
HYO4-110T230	1,5	1,1	230	3	5,9	25	2825	0,68	68	-	2000	371,3	9,35	4 x 1,5	1,7
HYO4-150T230	2	1,5	230	3	8,2	27,5	2830	0,64	70	-	2000	386,3	10,2	4 x 1,5	1,7
HYO4-220T230	3	2,2	230	3	10,6	39,5	2815	0,70	72	-	2000	436,3	11,65	4 x 1,5	1,7
HYO4-300T230	4	3	230	3	12,8	39,5	2830	0,81	75	-	3000	481,3	14,9	4 x 1,5	1,7
HYO4-400T230	5,5	4	230	3	15,6	86	2840	0,83	76	-	5000	609,5	20,05	4 x 2	2,7
HYO4-550T230	7,5	5,5	230	3	22,7	109	2825	0,78	79	-	5000	699,5	24,65	4 x 2	2,7

Three phase submersible motors 50Hz 400V oil filled

Type	P ₂ [Hp]	P ₂ [kW]	Voltage [V]	Ph	I _n [A]	I _{avv} [A]	rpm	φ cos	η [%]	Capacitor [μF]	Thrust load [N]	Length A [mm]	Weight [kg]	Cable section [mm ²]	Cable Length [m]
HYO4-037T400	0,5	0,37	400	3	1,8	5,8	2850	0,54	58	-	2000	311,3	6,45	4 x 1,5	1,7
HYO4-055T400	0,75	0,55	400	3	2	8	2835	0,65	63	-	2000	331,3	7,2	4 x 1,5	1,7
HYO4-075T400	1	0,75	400	3	2,5	9,4	2825	0,77	63	-	2000	356,3	8,45	4 x 1,5	1,7
HYO4-110T400	1,5	1,1	400	3	3,4	15,5	2825	0,69	68	-	2000	371,3	9,35	4 x 1,5	1,7
HYO4-150T400	2	1,5	400	3	4,8	18	2835	0,63	71	-	2000	386,3	10,2	4 x 1,5	1,7
HYO4-220T400	3	2,2	400	3	6,1	39,5	2810	0,69	72	-	2000	436,3	11,65	4 x 1,5	1,7
HYO4-300T400	4	3	400	3	7,1	39,5	2835	0,69	75	-	3000	481,3	14,9	4 x 1,5	1,7
HYO4-400T400	5,5	4	400	3	9,2	49,5	2845	0,83	76	-	5000	609,5	20,05	4 x 2	2,7
HYO4-550T400	7,5	5,5	400	3	11,7	64	2835	0,86	79	-	5000	699,5	24,65	4 x 2	2,7
HYO4-750T400	10	7,5	400	3	16,4	88	2840	0,81	81	-	5000	799,5	28,95	4 x 2	2,7

Technical Specifications

Motor/Pump Flange	4" Nema Standard
Degree of protection	IP 68
Insulation Class	F
Voltage tolerance	- 10% / + 10%
Pumped liquid temperature	0°C - 35°C 32°F - 95°F
Min. Cooling Flow	0,1 m/s 0,328 ft/s
Max. Starts / Hour	30
Mounting	Vertical And/Or Horizontal
Max. Immersion Depth	200M
Thrust Load	From 0,5 to 3 Hp 2000N From 3 to 4 Hp 3000N From 5,5 to 10 Hp 5000N

Single Phase Version: Psc Type
(Permanent Split Capacitor)

Rewindable Motor Version

Cables, Voltage, Thrust Loads [...]
Special Versions Available.



HYA4

4" Water cooled Submersible motors Canned type

4" Water cooled submersible motors, canned type

Motors designed to work in 4" or wider wells. The use of very high quality materials and our strict tests together with consolidated know how ensure high mechanical resistance and high performing electrical features. All parts in contact with water are in AISI 304 stainless steel which ensures resistance to corrosion even in the most extreme conditions of use.

Product features

Stator:

With 24 slots, specially developed to achieve maximum electrical performance. Airtight sealed and resin encapsulated. A solution which ensures excellent heat exchange and extremely high mechanical resistance with high pressure, something typical of very deep immersions.

Removable Power Cable-Connector:

It ensures perfect sealing in the most critical conditions and it aids maintenance operations. The power cable complies with all major standards on the use in drinking water (KTW, ACS, WRAS).

Filling Liquid:

Mixture of water and propylene glycol to ensure adequate lubrication of the thrust bearing system together with the ability to lower the freezing point when stored in very cold places.

Restore Liquid Valve:

It allows water in to restore internal level.

Shaft:

Carbon-steel alloys in the rotor area, to foster electrical features. AISI 304 stainless steel projection. DUPLEX, a special type of stainless steel, replaces AISI 304 in motors bigger than 3Hp. This steel combines excellent resistance to corrosion and high mechanical resistance, which is necessary where static torque becomes really important.

Thrust Bearing System:

Kingsbury-type with stainless steel thrust bearing runners oscillating on a self-aligning system. A special runner lapping process makes this system extremely reliable and efficient.

100% Tested:

All motors are tested at the end of the line.



Single phase submersible motors 50hz 230v water cooled

Type	P ₂ [Hp]	P ₂ [kW]	Voltage [V]	Ph	I _n [A]	I _{lav} [A]	rpm	φ cos	η [%]	Capacitor [μF]	Thrust load [N]	Length A [mm]	Weight [kg]	Cable section [mm ²]	Cable Length [m]
HYO4-037S230	0,5	0,37	230	1	3,5	12,5	2860	0,87	52	20	2000	237	6,8	4 x 1,5	1,7
HYO4-055S230	0,75	0,55	230	1	4,8	17,2	2855	0,88	57	25	2000	257	7,9	4 x 1,5	1,7
HYO4-075S230	1	0,75	230	1	5,7	19,7	2840	0,9	62	35	2000	272	9,1	4 x 1,5	1,7
HYO4-110S230	1,5	1,1	230	1	8,2	27,2	2845	0,91	64	40	2000	297	11,2	4 x 1,5	1,7
HYO4-150S230	2	1,5	230	1	10,5	36,4	2840	0,93	66	50	3000	332	13,4	4 x 1,5	1,7
HYO4-220S230	3	2,2	230	1	15,2	48,9	2840	0,93	67	70	3000	387	14,2	4 x 1,5	1,7
HYO4-370S230	5	3,7	230	1	25	98,8	2845	0,95	73	00	6500	634	27,8	4 x 2	2,7

Single phase submersible motors 50Hz 230V water cooled

Type	P ₂ [Hp]	P ₂ [kW]	Voltage [V]	Ph	I _n [A]	I _{lav} [A]	rpm	φ cos	η [%]	Capacitor [μF]	Thrust load [N]	Length A [mm]	Weight [kg]	Cable section [mm ²]	Cable Length [m]
HYA4-037T230	0,5	0,37	230	3	2,3	9,3	2855	0,57	71	-	2000	212	6,45	4 x 1,5	1,7
HYA4-055T230	0,75	0,55	230	3	2,8	14,0	2855	0,65	76	-	2000	237	7,2	4 x 1,5	1,7
HYA4-075T230	1	0,75	230	3	3,4	16,1	2850	0,72	77	-	2000	257	8,45	4 x 1,5	1,7
HYA4-110T230	1,5	1,1	230	3	5	26,0	2820	0,77	72	-	2000	272	9,35	4 x 1,5	1,7
HYA4-150T230	2	1,5	230	3	6,6	28,6	2835	0,80	71	-	3000	297	10,2	4 x 1,5	1,7
HYA4-220T230	3	2,2	230	3	9,8	41,1	2835	0,80	70	-	3000	332	11,65	4 x 1,5	1,7
HYA4-300T230	4	3	230	3	13	78,5	2855	0,79	73	-	3000	387	14,9	4 x 1,5	1,7
HYA4-400T230	5,5	4	230	3	17,2	89,4	2845	0,76	77	-	6500	574	20,05	4 x 2	2,7
HYA4-550T230	7,5	5,5	230	3	24,5	113,4	2850	0,76	74	-	6500	634	24,65	4 x 2	2,7

Single phase submersible motors 50Hz 400V water cooled

Type	P ₂ [Hp]	P ₂ [kW]	Voltage [V]	Ph	I _n [A]	I _{lav} [A]	rpm	φ cos	η [%]	Capacitor [μF]	Thrust load [N]	Length A [mm]	Weight [kg]	Cable section [mm ²]	Cable Length [m]
HYA4-037T400	0,5	0,37	400	3	1,4	6,0	2850	0,54	70	-	2000	212	5,8	4 x 1,5	1,7
HYA4-055T400	0,75	0,55	400	3	1,7	8,3	2855	0,62	75	-	2000	237	6,8	4 x 1,5	1,7
HYA4-075T400	1	0,75	400	3	2,1	9,8	2825	0,76	68	-	2000	257	7,9	4 x 1,5	1,7
HYA4-110T400	1,5	1,1	400	3	3,2	16,1	2825	0,68	73	-	2000	272	9,1	4 x 1,5	1,7
HYA4-150T400	2	1,5	400	3	4,1	18,7	2840	0,75	71	-	3000	297	11,2	4 x 1,5	1,7
HYA4-220T400	3	2,2	400	3	5,9	28,1	2830	0,78	69	-	3000	332	13,4	4 x 1,5	1,7
HYA4-300T400	4	3	400	3	7,9	48,4	2850	0,76	72	-	3000	387	18,9	4 x 1,5	1,7
HYA4-400T400	5,5	4	400	3	10,1	51,5	2850	0,74	77	-	6500	574	23,4	4 x 2	2,7
HYA4-550T400	7,5	5,5	400	3	13,9	66,6	2850	0,77	74	-	6500	634	27,8	4 x 2	2,7
HYA4-750T400	10	7,5	400	3	16,9	91,5	2845	0,76	74	-	6500	734	31,4	4 x 2	2,7

Technical Specifications

Motor/Pump Flange	4" Nema Standard
Degree of protection	IP 68
Insulation Class	F
Voltage tolerance	- 10% / + 10%
Pumped liquid temperature	0°C - 35°C 32°F - 95°F
Min. Cooling Flow	0,1 m/s 0,328 ft/s
Max. Starts / Hour	30
Mounting	Vertical And/Or Horizontal
Max. Immersion Depth	300M
Thrust Load	From 0,5 to 3 Hp From 3 to 4 Hp From 5,5 to 10 Hp
	2000N 3000N 5000N

Single Phase Version: Psc Type
(Permanent Split Capacitor)

Rewindable Motor Version

Cables, Voltage, Thrust Loads [...]
Special Versions Available.

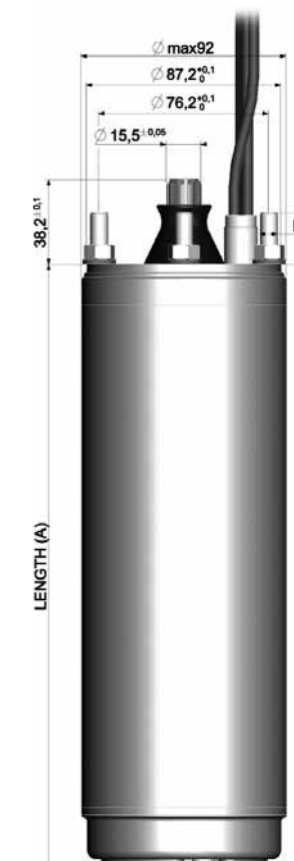

HY06

6" Rewindable oil Filled submersible Motors

6" Rewindable Oil Filled Submersible Motors

Motors designed to work in 6" or wider wells. The use of very high quality materials and our strict tests together with consolidated know how ensure high mechanical resistance and high performing electric features.

All parts in contact with water are in AISI 304 stainless steel. The power cable with removable connector ensures perfect water-tightness. Designed to be easily repairable.

Product features

External Sleeve And Bottom:

Made in AISI 304 stainless steel. More specifically, the sleeve is in 304L (Low Carbon) to avoid possible corrossions on the welding.

Upper Support:

Cast iron with cataphoresis treatment. Sleeve clamping is ensured for the whole series by 8 inserts.

Mechanical Seal:

Graphite/ceramic in the standard version; SIC-SIC version available upon request.

Ball Bearings:

Duly oversized to ensure a long lasting motor.

Stator:

Specifically developed to achieve maximum electrical yield. Airtight sealed and immersed in selected mineral white and highly refined oil, suitable to be used in drinking water (F.D.A., Food and Drug Administration, approved).

Removable Power Cable-Connector:

It ensures perfect sealing in the most critical conditions and it aids maintenance operations. More specifically, the connector prevents oil from rising in the conductors up to the joint, thus enabling immersion at greater depths. The power cable complies with all major standards on the use in drinking water (KTW, ACS, WRAS).

Shaft:

Carbon-steel alloys in the rotor area, to foster electrical features. DUPLEX stainless steel projection. This steel combines excellent resistance to corrosion and high mechanical resistance, which is necessary where static torque becomes really important.

100% Tested:

All motors are tested at the end of the line. An extremely effective seal check is also carried out on all motors.



Three phase submersible motors 50Hz 400V oil filled

Type	Voltage [V]	P ₂ [Hp]	P ₂ [kW]	Ph	I _n [A]	I _{avv} [A]	rpm	φ cos	η [%]	Thrust load [N]	Length A [mm]	Weight [kg]	Cable section [mm ²]	Cable Length [m]
HY06-400T400 DOL HY06-400T400 DS	400 400/690	5,5	4	3	9,1	47	2840	0,86	74	10000	595	34	4 x 4	3
HY06-550T400 DOL HY06-550T400 DS	400 400/690	7,5	5,5	3	12,8	66	2840	0,84	74	10000	625	41	4 x 4	3
HY06-750T400 DOL HY06-750T400 DS	400 400/690	10	7,5	3	16,8	81	2850	0,83	78	10000	660	46	4 x 4	3
HY06-920T400 DOL HY06-920T400 DS	400 400/690	12,5	9,2	3	21,2	98	2880	0,77	81	10000	700	48	4 x 4	3
HY06-1100T400 DOL HY06-1100T400 DS	400 400/690	15	11	3	22,9	123	2850	0,82	85	10000	765	52	4 x 4	3
HY06-1300T400 DOL HY06-1300T400 DS	400 400/690	17,5	13	3	27,6	141	2860	0,80	84	10000	820	57	4 x 4	3
HY06-1500T400 DOL HY06-1500T400 DS	400 400/690	20	15	3	30,7	158	2840	0,86	82	10000	820	58	4 x 4	3
HY06-1850T400 DOL HY06-1850T400 DS	400 400/690	25	18,5	3	38,0	231	2850	0,84	84	20000	883	64	4 x 8	4
HY06-2200T400 DOL HY06-2200T400 DS	400 400/690	30	22	3	45,5	258	2850	0,83	84	20000	953	71	4 x 8	4
HY06-2600T400 DOL HY06-2600T400 DS	400 400/690	35	26	3	52,0	296	2850	0,85	85	20000	1018	79	4 x 8	4
HY06-3000T400 DOL HY06-3000T400 DS	400 400/690	40	30	3	61,5	348	2860	0,83	85	20000	1098	87	4 x 8	4
HY06-3700T400 DOL HY06-3700T400 DS	400 400/690	50	37	3	76,0	396	2840	0,84	84	20000	1233	99	4 x 8	4



D. O. L. VERSION



Δ-Δ VERSION

Technical Specifications

Motor/Pump Flange	6" Nema Standard
Degree of protection	IP 68
Insulation Class	F
Voltage tolerance	- 10% / + 10%
Pumped liquid temperature	0°C - 35°C 32°F - 95°F
Min. Cooling Flow	0,1 m/s 0,328 ft/s
Max. Starts / Hour	30
Mounting	Vertical And/Or Horizontal (up to 15kW)
Max. Immersion Depth	300M
Thrust Load	
From 5,5 HP to 20 HP	10.000N
From 25 HP to 50 HP	20.000N

Rewindable motor

Cables, Voltage, Thrust Loads [...]
Special Versions Available.

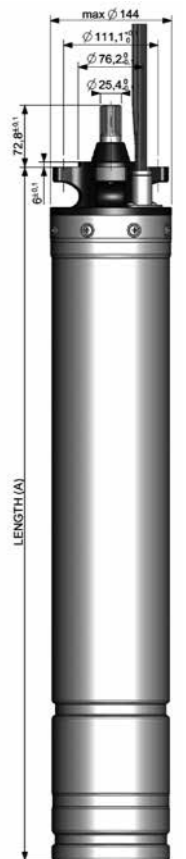

HYA6

6" Rewindable water Cooled submersible Motors

6" Rewindable Water Cooled Submersible Motors

Motors designed to work in 6" or wider wells. The use of very high quality materials and our strict tests together with consolidated know how ensure high mechanical resistance and high performing electric features. Designed to be easily repairable.

Product features

Stator:

Specifically developed to achieve maximum electrical yield. Covered by an AISI 304 stainless steel sleeve. Windings are asynchronous-type and are made of cooper wire with PVC insulation, or copper wire with PE2+PA insulation, which is "inverter resistant" and suggested for high temperatures and voltage surges.

Power cable:

It ensures perfect sealing in the most critical conditions. Cable is EPR-type and complies with all major standards on the use in drinking water (KTW, ACS, WRAS).

Filling Liquid:

Mixture of water and propylene glycol to ensure adequate lubrication of the thrust bearing system together with the ability to lower the freezing point when stored in very cold places.

Upper And Lower Support:

GS400 spheroidal cast iron with cataphoresis treatment, which gives great resistance to water impacts and corrosion.

Mechanical Seal:

SIC-SIC, silicon-silicon carbide.

Shaft:

Completely in AISI 420 stainless steel, without welding. It is ground along the entire axis thus giving the rotor such a concentricity to ensure perfect linearity. A shaft free from vibration is obtained thanks to balancing. Led by wear-resistant graphite bushing bearings.

Thrust Bearing System:

Bidirectional Michell-type, with pads in treated steel and supported by a disk in resin compound fibres and self lubricating additives, totally ecological.

100% Tested:

All motors are tested at the end of the line.



Electrical Data - 50Hz

Type	P [Hp]	P [kW]	I _n [A]		Starting		cos	[%]	rpm	Thrust load [N]	Length [mm]	Weight [kg]	Cable section [mm ²]				Cable Length [m]	T _{max}							
					Direct	Δ / Y							Direct		Δ / Y			H ₂ O	PE2 + I PA						
			230V	400V	I _a / I _n	I _a / I _n							230V	400V	230/400V	400/690V		PVC							
HYA6-400	5,5	4	16	9,5	5,2	1,3	0,83	79,5	2880	18000	640	41	4 x 3	4 x 3	4 x 6	4 x 6	3,5	30°C 86°F	55°C 131°F						
HYA6-550	7,5	5,5	21,5	12,5	4,9	1,6	0,87	78	2850		670	44													
HYA6-750	10	7,5	29,5	17	5,35	1,7	0,86	78,5	2850		700	46													
HYA6-920	12,5	9,2	36	21,5	5,05	1,7	0,86	78	2830		740	50													
HYA6-1100	15	11	42,5	24,5	5	1,6	0,87	79	2840		770	54													
HYA6-1300	17,5	13	51	29	5	1,6	0,86	80	2840		840	61													
HYA6-1500	20	15	60	34	5,05	1,6	0,86	81	2830	840	62	6 x 3	4 x 3	4 x 6	3,5	30°C 86°F	55°C 131°F								
HYA6-1850	25	18,5	69,5	40	4,85	1,6	0,86	82	2845	900	68														
HYA6-2200	30	22	83	48	4,6	1,5	0,86	83	2845	25000	970	75	10 x 3	6 x 3	6 x 6	3,5	25°C 77°F	45°C 113°F							
HYA6-2600	35	26	95	55	4,9	1,6	0,87	82,5	2830		1040	82													
HYA6-3000	40	30	113,5	65,5	5,15	1,7	0,85	83	2840		1100	89													
HYA6-3700	50	37	138,5	80	4,75	1,5	0,85	83	2840		1240	103							-	10 x 3	10 x 6	6 x 6	3,5	25°C 77°F	45°C 113°F
HYA6-4500	60	45	167	96,5	5,05	1,6	0,85	83	2840		1370	116							-						

Technical Specifications

Motor/Pump Flange	6" Nema Standard
Degree of protection	IP 68
Insulation Class	PVC: Y PE2 + PA: B
Voltage tolerance	- 10% / + 6%
Pumped liquid temperature	Refer to electrical data sheet
Min. Cooling Flow	0,15 m/s 0,492 ft/s
Max. Starts / Hour	10
Mounting	Vertical And/Or Horizontal (up to 15kW)
Max. Immersion Depth	350M
Thrust Load	
From 5,5 to 20 HP	18.000N
From 25 to 60 HP	25.000N

Rewindable motor

Special cables/Voltage/Thrust Loads,
Y/Δ Starting, Pt100 Temperature sensor [...]
Available Upon Request.

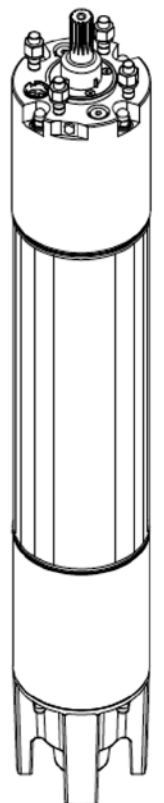

HYA8 HYA10

8"/10" Rewindable water cooled submersible motors

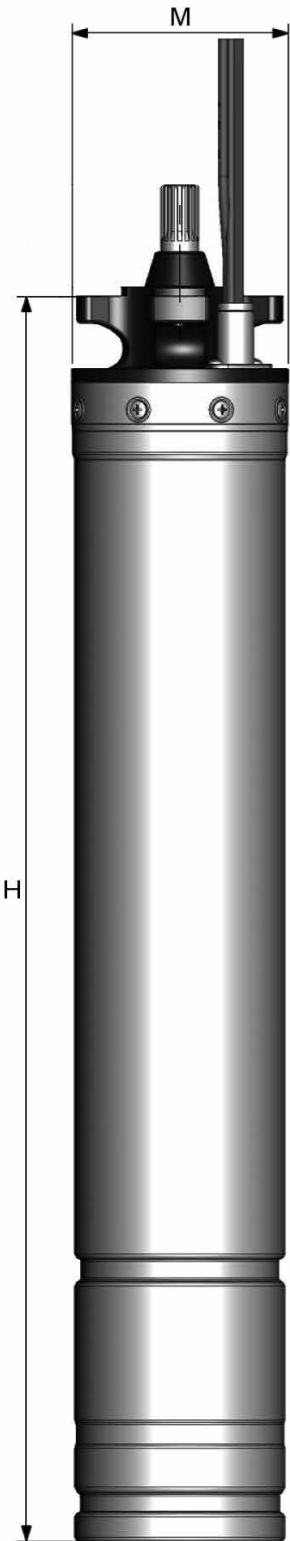

Electrical features - 2 poles - 50/60Hz

Nom. Ø	Motor type	Rated power		Rated current I_n		Efficiency η in %						cos ϕ Power factor			
		CV	kW	230V $\pm 5\%$	400V $\pm 5\%$	4/4	3/4	2/4	4/4	3/4	2/4	4/4	3/4	2/4	
8"	HYA8-4500	60	44	159	92	84	85	87	87	84	84	77			
	HYA8-5500	75	55	196,5	113,5	84,5	85,5	87,5	87,5	85	85	77,5			
	HYA8-6600	90	66	233	134,5	85	85,5	88	88	85	85	78			
	HYA8-7500	100	75	259	149,5	85	86	88	88	85	85	78			
	HYA8-9200	125	92	319,5	185	85	86	88	88	85	85	78			
10"	HYA10-7500	100	75	259	149,5	85	86	88	88	85	78				
	HYA10-9200	125	92	319,5	185	86	85,5	88	88	85	78				
	HYA10-11000	150	110	379	219	86	85,5	89	89	86	79				
	HYA10-12900	175	129	440	254,5	85,5	86,5	90	90	87	80				

Nom. Ø	Motor type	Starting mode				Axial thrust daN	Max. water temp. °C	Starts /h
		DOL		Y-Δ	Statoric			
		C_s/C_n	I_s/I_n	I_s/I_n	I_s/I_n			
8"	HYA8-4500	1,95	5,7	2	3,7	4500	30	10
	HYA8-5500	1,95	5,8	2	3,7			
	HYA8-6600	1,85	5,8	2	3,6			
	HYA8-7500	1,8	5,7	1,9	3,5			
	HYA8-9200	1,8	5,7	1,9	3,5			
10"	HYA10-7500	1,8	6,4	1,9	3,4	4500	30	6
	HYA10-9200	1,7	6,3	1,9	3,4			
	HYA10-11000	1,6	6,7	1,8	3,3			
	HYA10-12900	1,55	6,5	1,8	3,3			

C_s : Starting torque - C_n : Nominal torque - I_s : Starting current - I_n : Nominal current

Protection: IP 68

Insulation: Class F

Service factor: 50Hz=1 60Hz=1,2

Direction of rotation (view from shaft projection side: anti-clockwise)

Horizontal installation is allowed with 8° minimum slope.

Material versions: Cast iron, Stainless steel (AISI304, AISI316 or AISI904) wet parts.

Winding options: PVC/PPC or PE2+PA on demand.

Kingsbury type thrust bearing

Temperature sensor PT100/PTC on demand

Sand protected silicon carbide mechanical seal.

Control panels available on demand.

Cooling sleeves available on demand.

Coupling flange

8" Submersible motors
NEMA standard

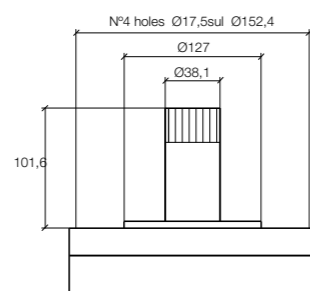

10" Submersible motors

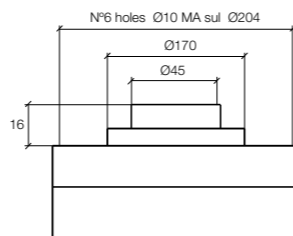

Overall dimensions

Nom. Ø	Motor type	H mm	M mm	Cable outlet				Length m	Position	Motor weight kg
				Cross section mm ² Starting mode						
				DOL		Y-Δ				
				230V $\pm 5\%$	400V $\pm 5\%$	230/400V	400/690V			
8"	HYA8-4500	1220	194	3x(1x25)	3x(1x16)	6x(1x16)	6x(1x10)	3	A	169
	HYA8-5500	1370								196
	HYA8-6600	1490		6x(1x25)	3x(1x25)	6x(1x25)	6x(1x16)			229
	HYA8-7500	1590								244
	HYA8-9200	1740								256
10"	HYA10-7500	1410	240		3x(1x35)		6x(1x25)	3	B	305
	HYA10-9200	1540								355
	HYA10-11000	1730		3x(1x50)			6x(1x35)			405
	HYA10-12900	1910								465

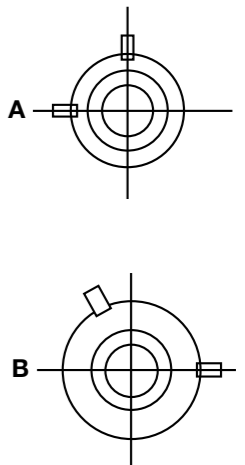

Electric cables - Maximum length

230V 3 phase		DOL or STATORIC STARTING						
Motor		3 cables 1x... mm ²						
		50	70	95	120	150	185	240
kW	HP	Max. length (m)						
45	60	84*	120	162	206	257	317	410

400V 3 phase		DOL or STATORIC STARTING										
Motor		1 cable 3 x...mm ²		3 cables 1x... mm ²								
		25	35	50	70	95	120	150	185	240	300	400
kW	HP	Max. length (m)										
45	60	140	196	258	362							
55	75	108*	152	213	298	404						
66	90		135*	178	249	338	426					
75	100			151*	211	286	362					
90	125				165	224	283	354	437			
110	150				142*	182	243	304	375			
132	180					157*	198	247	305	295		
147	200						174	228	281	364		
170	230							200	246	319	398	
191	260								220	285	358	
220	300									248	307	408
250	340									219	274	365

230V 3 phase		Y-Δ STARTING								
Motor		2 cables 3 x... mm ²		6 cables 1x...mm ²						
		25	35	50	70	95	120	150	185	240
kW	HP	Max. length (m)								
45	60	71	100	137	192	261	329	396		
55	75		79	113	158	216	272	341		
66	90		64	95	133	180	228	285	351	
75	100			81	113	164	194	242	301	390

400V 3 phase		Y-Δ STARTING											
Motor		2 cables 3 x...mm ²				6 cables 1x mm ²							
		10	16	25	35	50	70	95	120	150	185	240	
kW	HP	Max. length (m)											
45	60	87*	138	217	304	412							
55	75		108*	171	239	341							
66	90			138	193	285	400						
75	100			117	164	242	339	460					
90	125				128	189	264	359	453				
110	150					166	233	315	398				
132	180						136*	190	258	325	406		
147	200							176	239	300	376		
170	230								210	263	330	407	
191	260								187	234	294	362	
220	300									202	254	312	406
250	340									180*	228	278	361

(*) For neoprene cable only.

Tables are referred to water 30 °C. If temperature is higher please apply our technical department.

0,2m/s recommended flow for water cooling.

Maximum immersion depth: 250m.

For 415 V the cables length shown in the 380 tables can be increased by 10%.

hydroo®

Be pumping partners

HYDROO
Pump Industries SL

Carrer La Banyeta Nova, 11
Polígon Industrial La Banyeta
17843 Palol de Revardit
Catalonia. Spain
Tel. +34 972 394 654
E-mail: info@hydroo.com
www.hydroo.com

202112-CTL-SX&SN-EN
subject to amendments

